



MBA

*built to be
Tough*



Unit A, 11/F., Block A, Marvel Industrial Building, No.25-31,

Kwai Fung Crescent, Kwai Chung, N.T., Hong Kong.

Tel: (852) 2409 7786 Fax: (852) 2409 4232, 2409 0837

E-mail: sales@metrobearing.com

Home page: <http://www.metrobearing.com>

New Product

- Air Brake Chamber (for Disc Brake Application)

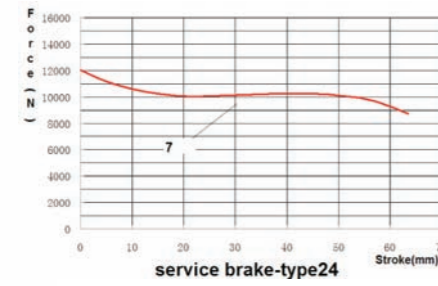

24 INCH AIR BRAKE CHAMBER

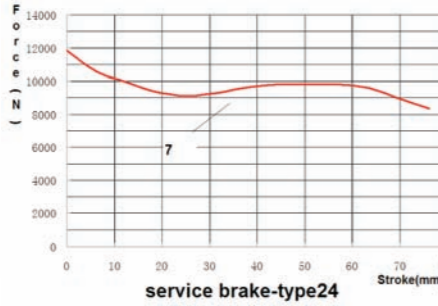

24L INCH AIR BRAKE CHAMBER (LONG STROKE)

Spring Brake Chamber (for Disc Brake Application)

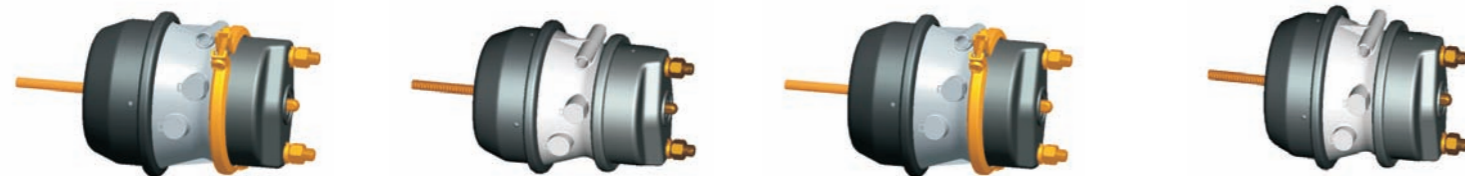

P/N:	STROKE (MM)	APPLY PRESSURE (BAR)	APPLY PUSH ROD LENGTH	REMARK
CHAMBER-DS1424	64	8	15±0.5	REPAIRABLE
CHAMBER-DS1424R	64	8	15±0.5	PERMANENT SEALED
CHAMBER-DS1424L	76	8	15±0.5	REPAIRABLE
CHAMBER-DS1424LR	76	8	15±0.5	PERMANENT SEALED
CHAMBER-DS1824	64	8	15±0.5	REPAIRABLE
CHAMBER-DS1824R	64	8	15±0.5	PERMANENT SEALED
CHAMBER-DS1824L	76	8	15±0.5	REPAIRABLE
CHAMBER-DS1824LR	76	8	15±0.5	PERMANENT SEALED
CHAMBER-DS2224	64	8	15±0.5	REPAIRABLE
CHAMBER-DS2224R	64	8	15±0.5	PERMANENT SEALED
CHAMBER-DS2224L	76	8	15±0.5	REPAIRABLE
CHAMBER-DS2224LR	76	8	15±0.5	PERMANENT SEALED
CHAMBER-DS2430	64	8	15±0.5	REPAIRABLE
CHAMBER-DS2430R	64	8	15±0.5	PERMANENT SEALED
CHAMBER-DS2430L	76	8	15±0.5	REPAIRABLE
CHAMBER-DS2430LR	76	8	15±0.5	PERMANENT SEALED
CHAMBER-DS3030	64	8	15±0.5	REPAIRABLE
CHAMBER-DS3030R	64	8	15±0.5	PERMANENT SEALED
CHAMBER-DS3030L	76	8	15±0.5	REPAIRABLE
CHAMBER-DS3030LR	76	8	15±0.5	PERMANENT SEALED

- Piston Type Chamber



DP24MB



D2724MB

- Disc Brake(Single Tappet PDB)

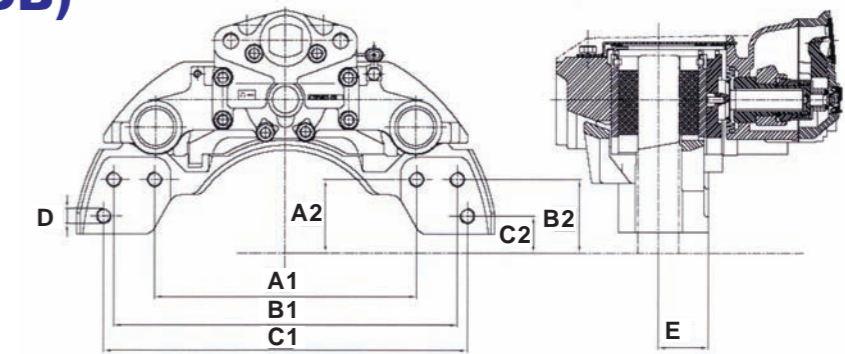

No.	Wheel Size	Item ID	A1	A2	B1	B2	C1	C2	D	E	Disc Size (Diameter X Thickness)	Brake Radius	Brake Torque (kNm)
1	17.5'	STAPDBAD01	228	64	288	64	310	36	6-M14x1.5	41	∅ 330 x 34	127	10
2	19.5'	STAPDBAD02	266	67	341	67	360	30	6-M16x1.5	56	∅ 385 x 45	152	13
3	16'	STAPDBAD04	236	56	282	26	—	—	4-M16x1.5	39	∅ 296 x 34	112	7

- Disc Brake(Double Tappet PDB)

Radial Air Chamber Double Tappets PDB

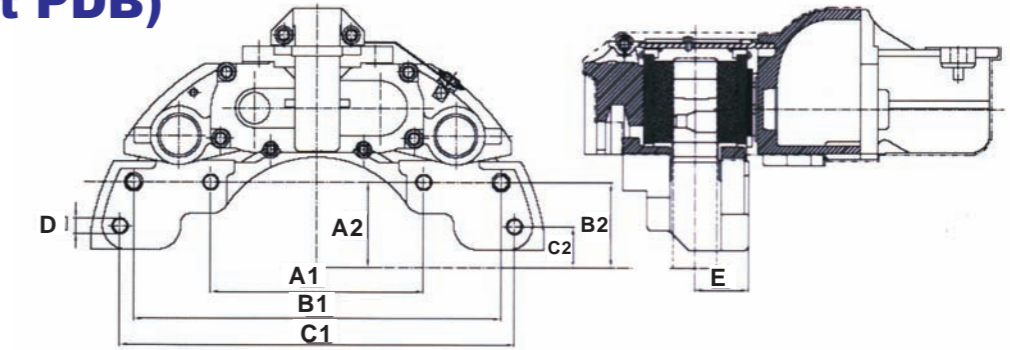

No.	Wheel Size	Item ID	A1	A2	B1	B2	C1	C2	D	E	Disc Size (Diameter X Thickness)	Brake Radius	Brake Torque (kNm)
1	22.5'	DTAPDBDR01	326	40	406	49	—	—	4-M20x1.5	55	∅ 430 x 45	173.6	22
2	22.5'	DTAPDBDR01A	220	87	380	87	408	42	6-M16x1.5	55	∅ 430 x 45	175.5	22
3	22.5'	DTAPDBDR01B	235	80	378	80	400	40	6-M20x1.5	55	∅ 430 x 45	175.5	22
4	22.5'	DTAPDBDR01C	294	76	380	87	408	42	6-M18x1.5	55	∅ 430 x 45	173.6	22
5	20'	DTAPDBDR02	275	78	348	78	366	45	6-M16x1.5	48	∅ 395 x 34	163.8	13

Axial Air Chamber Double Tappets PDB

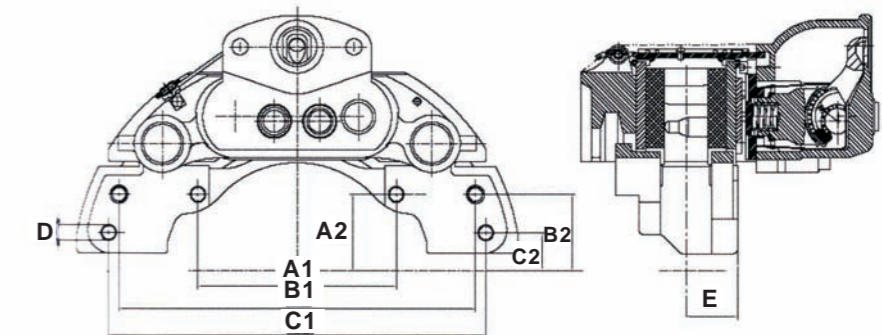
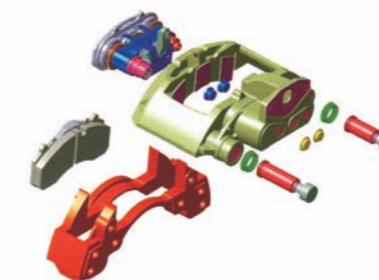

No.	Wheel Size	Item ID	A1	A2	B1	B2	C1	C2	D	E	Disc Size (Diameter X Thickness)	Brake Radius	Brake Torque (kNm)
1	22.5'	DTAPDBDA03	210	80	378	80	400	40	6-M16x1.5	55	∅ 430 x 45	173.6	22
2	22.5'	DTAPDBDA03A	326	40	406	49	—	—	4-M20x1.5	55	∅ 430 x 45	173.6	22
3	22.5'	DTAPDBDA03B	290	75	378	80	400	40	6-M20x1.5	55	∅ 430 x 45	173.6	22
4	22.5'	DTAPDBDA03C	235	80	378	80	400	40	6-M20x1.5	55	∅ 430 x 45	173.6	22
5	22.5'	DTAPDBDA03D	326	40	406	49	—	—	4-M20x1.5	55	∅ 430 x 45	173.6	22
6	22.5'	DTAPDBDA03E	220	75	378	75	400	35	6-M20x1.5	55	∅ 430 x 45	173.6	22
7	20'	DTAPDBDA05	266	67	341	67	360	30	6-M16x1.5	55	∅ 395 x 45	163.8	18
8	20'	DTAPDBDA05A	341	67	360	30	—	—	4-M18x1.5	55	∅ 395 x 45	163.8	18
9	20'	DTAPDBDA05B	310	67	366	35	—	—	4-M20x1.5	55	∅ 395 x 45	163.8	18
10	20'	DTAPDBDA05C	230	70	348	70	366	35	6-M16x1.5	55	∅ 395 x 45	163.8	18
11	20'	DTAPDBDA05D	210	80	340	75	370	42	6-M20x1.5	55	∅ 395 x 45	163.8	18
12	20'	DTAPDBDA05E	310	67	366	35	—	—	4-M20x1.5	55	∅ 395 x 45	163.8	18

Company Profile

“Quality is fundamental, Safety comes first” .

Metro Bearing & Automotive Limited, a specialist in truck and trailer components, located in Hong Kong has expanded remarkably over the last 10 years, dealing with wide range of automotive parts and accessories. With the joint venture factory established and the spring brake chamber came on production, it rapidly brought the company grown up into one of the leading suppliers in the market in few years time. The success encouraged the company continues to enter into new market segment by developing advanced models. As today's vehicles and trailers have become more and more sophisticated, the demand for quality is much higher than ever. Our persistent aim is to provide high quality parts for customers along with professional knowledge and service expertise.

All the products are manufactured at our own MBA & BTC brand and on OEM basis, distributed to both domestic and overseas customers in semi-trailer markets including China, Canada, USA, Mexico, Peru, Columbia, Australia, U.K, France, Italy, South Africa, Israel, Taiwan, Korea, Malaysia. A complete sales network and after-sales services have been successfully established. The product portfolio includes air brake chambers, slack adjusters, bearings, air valves, camshafts, landing gears, oil seals, repair kits, flare kits... and brings in new products each day.

The company has two factories located in Taishan and Shunde. The factories have a total area of 900,000 square feet and a strong, professional team of more than 250 highly skilled and experienced engineers and personnel to serve the customers. There are over 70 sets of various CNC equipment and advanced production machinery. Both factories have already obtained ISO/TS16949 certification.

The company aims to provide the best service and quality products to our customers. We believe good service is our business and quality is of the utmost important. A great deal of resources is put in the automotive product developments, production and quality assurance. Continuous improvement is our primary objective to strive for the maximum in safety.

Through different product testing and third party inspection, it demonstrated our products have achieved a very high level of conformity to safety requirement.

- **Vision**
Efficient organization and create value for the whole industry.
Integrity and customer satisfaction.
Mutual growing in partnership.
- **Mission**
Better than the past.
Better than competitors.
More than customers' expectations.

- **History**
1997 Metro Bearing & Automotive Limited was founded in Hong Kong.
1998 First factory was setup in Panyu and started production of auto parts and accessories.
2002 Factory was moved to new premises in Dongguan and named MBA-BTC Inc. with 40,000 sq.ft. area.
2002 MBA-BTC Inc. obtained QS-9000 certification.
2003 A joint venture company FUWA-BTC Company Limited was established, a new factory was setup in Shunde with an area of 430,000 sq.ft mainly for the production of spring brake chambers and slack adjusters.
2006 FUWA-BTC Company Limited obtained ISO/TS16949 certification.
2007 MBA-BTC Inc. obtained ISO/TS16949 certification.
2012 The construction of a brand new factory located in Taishan, Guangdong is proceeding in high gear for new product lines. The first phase covers an area of 400,000 sq.ft. and is opening on MARCH, 2012.



Our Factory

MBA HEAVY DUTY PARTS INC. is mainly for the production of bearings, auto parts and accessories. Most of the products are on OEM basis or under our own MBA & BTC brand. About 85% of the products are exported to the North and South American and European markets. The rest is selling to Middle East and Asian countries.

FUWA-BTC Company Limited is primary for the production of spring brakes, air brake chambers, manual and automatic slack adjusters. There are more than 100 types of chambers and slack adjusters. Over 70% of the products are selling to the auto parts manufacturers in China. The rest are on OEM basis mainly for export all over the world.

Product Qualification

Our products meet all of the requirements for both domestic and overseas markets. We passed the inspection by both Chongqing Auto Research Centre and also DANA corporation in June 2006. In order to certify our high quality, we became the first company in China to pass both the Germany TUV and America Dynamometer testing. The results show that our products have already exceeded SAE J1469 standards. Results of these two tests more than double the China National Standards.

We have developed a new generation of auto slack adjuster. It can record clearance increase caused by friction according to the clearance induction principle. It adjusts clearance when minimum torque brings the brake shoe back. So it avoids the elastic clearance influence of the brake system. This can ensure the same brake result of all wheels. Thus braking is safe, reliable, and no manual adjustment is needed. The braking clearance will be controlled between 0.2-0.7mm according to China National Standard. It ensures normal operation under bad and special condition for its leading standards SAE J1462 and SAE J1513.



Link Test #	007483	Link Testing Laboratories, Inc.	Cost Ref.	T2006P1
Test Description Link Chamber Test				
Test Information				
Test Requestor:	Fuwa-BTC	Test Requested By:	Chen Liao	
Test Procedure:	FUWA01310	Test Procedure:	FUWA01310	
Link Control Program:	100000100	Dynamometer:	TD	
Part No.:	87719	Part No.:	87719	
Test Coordinator:	Richard Strahan Sr.	Test Technician:	818 JL	
Date Started:	11/30/05	Date Completed:	12/01/05	
Date Parts Received:	11/27/05	Date Parts Received:	11/27/05	
Testing Center:	3-38			
Dynamometer Information				
Rolling Radius:	19.8 inch	497.8 mm		
Required Wheel Load:	11300 lb	5115 kg		
Actual Wheel Load:	11300 lb	5117 kg		
Required Air Weight:	23000 lb	10433 kg		
Required Inertia:	983.3 slug-ft ²	1332.4 kg-m ²		
Actual Inertia:	983.2 slug-ft ²	1332.1 kg-m ²		
Air Chamber:	T2006P1			
Brake Adjuster:	100000100			
Brake Information				
Brake Type:	CLASS EIGHT TRAILER			
Brake Size:	9.8 x 7			
Apply P/N:	400000004			
Push/Release Linking:	MAX12 FF 4N10			
Brake/Trail Linking:	MAX12 FF 4N10			
Chamber Type:	CA01			
Brake Orientation:	L/R			
Final Comments:				
1. The test information shown should be kept from the customer's required data.				
2. The test results are provided and stored for the customer's review.				
3. The test results are stored for the customer's review.				
Link		File	Date	
Signature:		ENCLOSURE	11/30/05	
Link Testing Laboratories, Inc. 100000100				

Product Testing

Diaphragm hardness testing machine



Durability test



Cycle test



Electronic universal testing machine



High/low temperature test machine



Proof pressure test



Profile projector

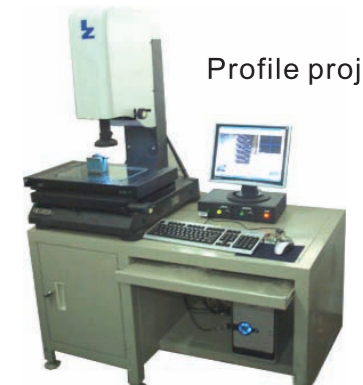

Salt spray test



Auto slack function test



Our Achievement

- We are supplying to the Key Players of different countries and are reliable partners of Original Equipment Manufacturer.
- We have product liability insurance and warranty claim .
- We produced over 45,000,000 pieces in 8 years.

QUALITY IS FUNDAMENTAL, SAFETY COMES FIRST



United States / America



Argentina



Australia



Belgium



Bolivia



Brazil / Brasil



Canada



Chile



Colombia



Costa Rica



Denmark



Ecuador



El Salvado



Estonia



France



Germany



Guatemala



Hong Kong



India



Iran



Italy



Japan



Korea, South



Malaysia



Mexico



Netherlands



Nigeria



Norway



Panama



Peru

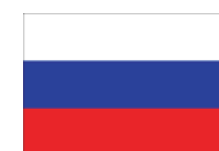

Russia



Saudi Arabia



Singapore



South Africa



Spain



Russia



Tunisia



Turkey



United Kingdom



Venezuela

Product Index

	PAGE		PAGE
New Products	1	Clutch Release Bearing	25
Air Brake Chamber(for Disc Brake Application)	1	Camshaft	26
Spring Brake Chamber(for Disc Brake Application)	1	Camshaft Repair Kit	27
Piston Type Chamber	1	Cord	29
Disc Brake(Single Tappet PDB)	2	Conspicuity Tape	31
Disc Brake(Double Tappet PDB)	2	Exhaust Clamp	31
Company Profile	3	Fifth Wheel	32
Our Factory	4	Flare Kit	32
Product Qualification	4	Hub Cap	32
Product Testing	4	King Pin	33
Our Achievement	5	Landing Gear	34
Air Brake Chamber	6	Leaf Spring	35
Piggyback Kit	7	Mud Flap Hanger	35
Air Brake Diaphragm	8	Mud Flap	35
Clevis	8	Oil Seal	35
Air Brake Hose	8	Plug & Socket	36
Air Brake Hose Fitting	8	Slack Adjuster (Manual)	37
Air Dryer & Cartridge	9	Slack Adjuster (Automatic)	39
Air Spring	9	Suspension Series	41
Air Valve	10	U-Bolt	43
Axles	13	U-Bolt Kit	43
Bearing (Pilot Bearing)	13	Wheel Hub	43
Bearing (Tapered Roller Bearing)	14	Wheel Rim	44
Bearing (Wheel Hub Unit)	14	Wheel Stud & Nut	44
Bearing (U-Joint)	17	Other Accessories	45
Brake Drum	20	- Truck Hinge & Lock	45
Brake Shoe/ Lined Shoe Kit	20	- Van Rack	45
Brake Repair Kit	21	- World Class Products Professionals Services	46
Center Support Bearing	23	- Wireless Back Up System	46

Air Brake Chamber

	<p>9 INCH SERVICE CHAMBER P/N : CHAMBER-T9EB Stroke : 45mm (1.75")</p>		<p>20 INCH SERVICE CHAMBER (LONG STROKE) P/N : CHAMBER-T20LEB Stroke : 76mm (3")</p>
	<p>12 INCH SERVICE CHAMBER P/N : CHAMBER-T12EB Stroke : 45mm (1.75")</p>		<p>24 INCH SERVICE CHAMBER P/N : CHAMBER-T24EB Stroke : 64mm (2.5")</p>
	<p>16 INCH SERVICE CHAMBER P/N : CHAMBER-T16EB Stroke : 57mm (2.25")</p>		<p>24 INCH SERVICE CHAMBER (LONG STROKE) P/N : CHAMBER-T24LEB Stroke : 76mm (3")</p>
	<p>20 INCH SERVICE CHAMBER P/N : CHAMBER-T20EB Stroke : 57mm (2.25")</p>		<p>30 INCH SERVICE CHAMBER (LONG STROKE) P/N : CHAMBER-T30LEB Stroke : 76mm (3")</p>



30 INCH SERVICE CHAMBER
P/N : CHAMBER-T30EB
Stroke : 64mm (2.5")



30 INCH SERVICE CHAMBER
P/N : CHAMBER-T30EY
Stroke : 64mm (2.5")



12/16 INCH SPRING BRAKE
P/N : CHAMBER-T1216EB
Stroke : 45mm (1.75")



24/24 INCH SPRING BRAKE
P/N : CHAMBER-T2424EB
Stroke : 64mm (2.5")



16/24 INCH SPRING BRAKE
P/N : CHAMBER-T1624MB
Stroke : 64mm (2.5")



24/24 INCH SPRING BRAKE
P/N : CHAMBER-T2424EY
Stroke : 64mm (2.5")



20/24 INCH SPRING BRAKE
P/N : CHAMBER-T2024EY
Stroke : 64mm (2.5")



24/30 INCH SPRING BRAKE
P/N : CHAMBER-T2430MB
Stroke : 64mm (2.5")



24/30 INCH SPRING BRAKE (LONG STROKE)
P/N : CHAMBER-T2430LMY
Stroke : 76mm (3")



24/30 INCH SPRING BRAKE
P/N : CHAMBER-T2430EY
Stroke : 64mm (2.5")



30/30 INCH SPRING BRAKE
P/N : CHAMBER-T3030MB
Stroke : 64mm (2.5")



30/30 INCH SPRING BRAKE
P/N : CHAMBER-T3030EY
Stroke : 64mm (2.5")



30/30 INCH SPRING BRAKE
P/N : CHAMBER-T3030ER
Stroke : 64mm (2.5")



30/30 INCH SPRING BRAKE (SEALED)
P/N : CHAMBER-T3030EBR
Stroke : 64mm (2.5")



30/30 INCH SPRING BRAKE (LONG STROKE)
P/N : CHAMBER-T3030LEBR
Stroke : 76mm (3")

Piggyback kit



P3030EBSK P3030LEBSK

Air Brake Diaphragm

Good quality with reinforcing material

P/N	DESC.	P/N	DESC.
DIAPHRAGM-9"	5"	DIAPHRAGM-20" & 20"L	6 1/2"
DIAPHRAGM-12"	5 1/2"	DIAPHRAGM-24" & 24"L	7"
DIAPHRAGM-16" & 16"L	6"	DIAPHRAGM-30" & 30"L	8"



Clevis

P/N	Description				Type
	A	B	C	D	
YA38050	1.88"	5/8"-18UNF	1/2"	9/16"	1
YA38056	2.00"	1/2"-20UNF	1/2"	9/16"	1
YA38057	2.00"	5/8"-18UNF	5/8"	9/16"	1
YA38058	2.00"	5/8"-18UNF	1/2"	9/16"	1
YA38059	1.75"	M16*1.5	1/2"	14.5 mm	1
YA38060	65 mm	5/8"-18UNF	1/2"	14.5 mm	2
YA38061	2.31"	5/8"-18UNF	1/2"	14.5 mm	1
YA38062	1.75"	M16*1.5	13.8 mm	14.5 mm	1
YA38063	65 mm	M16*1.5	13.8 mm	14.5 mm	2
YA38064	56 ~ 122 mm	M16*1.5	13.8 mm	14.5 mm	3
YA38065	1.75"	5/8"-18UNF	1/2"	14.5 mm	1
YA38066	1.75"	M16*1.5	5/8"	14.5 mm	1
YA38067	1.75"	5/8"-18UNF	5/8"	14.5 mm	1
YA38068	1.75"	5/8"-18UNF	13.8 mm	14.5 mm	1
YA38069	1.75"	1/2"-20UNF	1/2"	14.5 mm	1
YA38070	2.31"	1/2"-20UNF	1/2"	14.5 mm	1

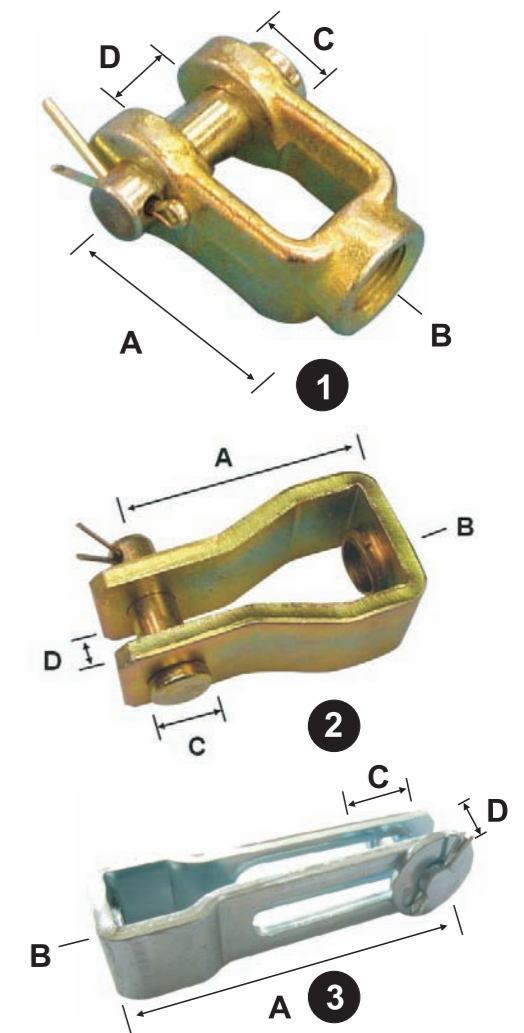

Air Brake Hose



MODEL 452711Y/B/R
 SIZE: 100×18 100×20
 100×22 100×25
 AIR INLET
 THREAD: Z 1/4"、Z 1/2"、Z 3/8"

Air Brake Hose Fitting

- Meets or Exceeds SAE and DOT FMVSS 571.106 Air Brake Specifications
- Manufactured from CA360 and CA345 Brass
- Use with SAE-J844 Type A & B Nylon Tubing
- Working Pressures up to 150 PSI and Temperature Range of -40° to +200° F
- Excellent Vibration Resistance
- No Special Tubing Preparation
- Easy Assembly

• **Union Tee**

P/N	Size	Replace Dayton
ABF-UT14	1/4	12-09984
ABF-UT38	3/8	12-09986
ABF-UT12	1/2	12-09988

• **90° Male Elbow**

P/N	Size	Replace Dayton
ABF-ME3814	3/8-1/4	12-09937
ABF-ME3838	3/8-3/8	12-09938
ABF-ME1238	1/2-3/8	12-09939
ABF-ME1212	1/2-1/2	12-09941



P/N: B512133 REPLACE: 512133
 Brand Model Year
 CHRYSLER CIRRUS 1997-1995
 SEBRING 1997-1996
 DODGE STRATUS 1997-1995
 PLYMOUTH BREEZE 1997-1996



P/N: B512136 REPLACE: 512136
 Brand Model Year
 CHRYSLER SEBRING 2005-1995
 DODGE AVENGER 2000-1995
 STRATUS 2005-2001
 EAGLE TALON 1998-1995
 MITSUBISHI ECLIPSE 2004-1995



P/N: B512149 REPLACE: 512149
 Brand Model Year
 FORD WINDSTAR 2003-1997



P/N: B512150 REPLACE: 512150
 Brand Model Year
 BUICK REGAL 1998-1997
 CENTURY 2002-1997
 CHEVROLET VENTURE 2005-1998
 OLDSMOBILE INTRIGUE PONTIAC 2002-1997



P/N: B512151 REPLACE: 512151
 Brand Model Year
 BUICK CENTURY 2003-1997
 REGAL 1996
 CHEVROLET LUMINA 2001-1996
 MONTE CARLO 1999-1996
 OLDSMOBILE CUTLASS SUPREME 1997



P/N: B512152 REPLACE: 512152
 Brand Model Year
 CHEVROLET CLASSIC 2005-2004
 MALIBU 2003-2001
 OLDSMOBILE ALERO 2004-1999
 PONTIAC GRAND AM 2005-1999



P/N: B513030 REPLACE: 513030
 Brand Model Year
 FORD ESCORT 2003-1991
 MAZDA 323 1995-1990
 MX-3 1996-1992
 PRPTEGE 2003-1990
 MERCURY TRACET 1999-1991



P/N: B513035 REPLACE: 513035
 Brand Model Year
 ACURA EL 2000-1997
 HONDA CIVIC 2000-1985
 CIVIC DEL SOL 1997-1993
 CRX 1991-1988
 WAGOVAN 1987-1986



P/N: B513044 REPLACE: 513044
 Brand Model Year
 BUICK REGAL 1196-1988
 CHEVROLET LUMINA 2001-1990
 MONTA CARLO 1999-1995
 OLDSMOBILE CUTLASS SUPREME 1997-1988
 PONTAC GRAMD PRIX 1996-1988



P/N: B513061 REPLACE: 513061
 Brand Model Year
 OLDSMOBILE BRAVADA 1997-1991
 GMC JIMMY 1997-1995
 SONOMA 1997-1991
 CHERVROLET BLAZER 1997-1995
 S10 1997-1992



P/N: B513011k REPLACE: 513011k
 Brand Model Year
 BUICK CENTURY 1989-1982
 CHEVROET CELEBRITY 1989-1982
 OLDSMOBILE CUTLASS CIERA 1989-1982
 PONTIAC 6000 1989-1982



P/N: B513012 REPLACE: 513012
 Brand Model Year
 OLDSMOBILE CUTLASS CALAIS 1991-1988
 CHEVROET CAVALIER 2005-1982
 BERETTA 1991-1987
 CADILLAC CIMARRON 1988-1982
 BUICK SKYHAWK 1989-1982



P/N: B513013 REPLACE: 513013
 Brand Model Year
 GMC S15 JIMMY 1990-1983
 CADILLAC ELDORADO 1985-1979
 EXCALIBUR PHAETON 1986-1984
 CHEVROLET CORVETTE 1996-1984
 BUICK RIVIERA 1985-1979
 OLDSMOBILE TORONADO 1985-1979



P/N: B513017k REPLACE: 513017k
 Brand Model Year
 BUICK SKYHAWK 1989-1984
 SKYLARK 1998-1986
 CADILLAC CIMARRON 1988-1984
 CHEVROLET BERETTA 1996-1987
 OLDSMOBILE ACHIEVA 1998-1992



P/N: B513018 REPLACE: 513018
 Brand Model Year
 BUICK CENTURY 2003-1983
 LESABRE 1992-1986
 REGAL 1993-1988
 CADILLAC DEVILLE 1990-1985
 CHEVROLET LUMINA 2001-1990



P/N: B513092 REPLACE: 513092
 Brand Model Year
 FORD THUNDERBIRD 1997-1991
 LINCOLN MARK VII 1992
 MARK VIII 1998-1993
 MERCURY COUGAR 1997-1991



P/N: B513100 REPLACE: 513100
 Brand Model Year
 FORD TAURUS 2007-1996
 LINCOLN CONTINENTAL 2002-1995
 MERCURY SABLE 2005-1996

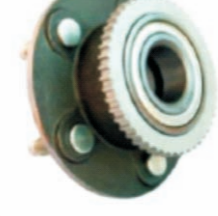

P/N: B513104 REPLACE: 513104
 Brand Model Year
 FORD CROWN VICTORIA 1997-1992
 LINCOLN TOWN CAR 1997-1992
 MERCURY GRAND MARQUIS 1997-1992



P/N: B513107 REPLACE: 513107
 Brand Model Year
 JEEP CHEROKEE 1989-1984
 COMANCHE 1989-1986
 WAGONEER 1989-1984
 WRANGLER 1989-1987



P/N: B513115 REPLACE: 513115
 Brand Model Year
 FORD MUSTANG 2004-1994



P/N: B513062 REPLACE: 513062
 Brand Model Year
 PONTIAC BONNEVILLE 1999-1991
 OLDSMOBILE 88 1999-1992
 LSS 1999-1996
 CADILLAC 60 APECIAL 1993
 BUICK LESABRE 1999-1991



P/N: B513074 REPLACE: 513074
 Brand Model Year
 CHRYSLER TOWN & COUNTRY 1995-1990
 DODGE CARAVAN 1995-1989
 GRAND CARAVAN 1995-1989
 PLYMOUTH GRAND VOYAGER 1995-1989
 VOYAGER 1995-1989



P/N: B513075 REPLACE: 513075
 Brand Model Year
 PLYMOUTH ACCLAIM 1995-1991
 SUNDANCE 1994-1991
 DODGE CARAVAN 1995-1991
 SPIRIT 1995-1991
 CHRYSLER DAYTONA 1993-1989



P/N: B513084 REPLACE: 513084
 Brand Model Year
 JEEP CHEROKEE 1999-1990
 COMANCHE 1992-1990
 WAGONEER 1990
 TJ 1999-1997



P/N: B513087 REPLACE: 513087
 Brand Model Year
 PONTIAC BONNEVILLE 1999-1992
 OLDSMOBILE 88 1999-1992
 CHEVROLET LUMINA APV 1996-1992
 CADILLAC 60 SPECIAL 1993
 BUICK CENTURY 1996-1994



P/N: B513089 REPLACE: 513089
 Brand Model Year
 CHRYSLER 300M 2004-1999
 CONCORDE 2004-1996
 DODGE INTREPID 2004-1993
 GAGLE VISION 1997-1993
 PLYMOUTH PROWLER 2001-1997



P/N: B513138 REPLACE: 513138
 Brand Model Year
 CHRYSLER CIRRUS 2000-1995
 SEBRING 2006-1996
 DODGE STRATUS 2006-1995
 PLYMOUTH BREEZE 2000-1996



P/N: B513156 REPLACE: 513156
 Brand Model Year
 FORD WINDSTAR 2003-1999



P/N: B513202 REPLACE: 513202
 Brand Model Year
 FORD CROWN VICTORIA 2002-1997
 LINCOLN TOWN CAR 2002-1997
 MERCURY GRAND MARQUIS 2002-1997



P/N: B515000 REPLACE: 515000
 Brand Model Year
 FORD AEROSTAR 1997-1990



P/N: B515001 REPLACE: 515001
 Brand Model Year
 GMC K1500 SUBURBAN 1994-1992
 K2500 SUBURBAN 1994-1992
 CHEVROLET BLAZER 1994-1992
 K2500 1994-1988



P/N: B513121 REPLACE: 513121
 Brand Model Year
 CHEVROLET INPALA 2001-2000
 CADOLAC DEVILLE 2001-1997
 BUICK CENTURY 2001-1997
 PARK AVENUE 2001-1997



P/N: B513123 REPLACE: 513123
 Brand Model Year
 CHEVROLER GRAND VOYAGER 2000
 TOWN & COUNTRY 2007-1996
 DODGE CARAVAN 2007-1996
 GRAND CARAVAN 2007-1996
 PLYMOUTH PROWLER 2001-1997



P/N: B513124 REPLACE: 513124
 Brand Model Year
 CHEVROLET BLAZER 2005-1997
 GMC JIMMY 2005-1997
 SONOMA 2004-1997
 ISUZU HOMBRE 2000-1998
 OLDSMOBILE BRAVADA 2001-1997



P/N: B513137 REPLACE: 513137
 Brand Model Year
 CHEVROLET CLASSIC 2005-2004
 MALIBU 2003-1997
 OLDSMOBILE ALERO 2004-1999
 CUTLASS 1999-1997
 PONTIAC GRAND AM 2005-1999



P/N: B515002 REPLACE: 515002
 Brand Model Year
 CHEVROLET K1500 1991-1988
 GMC K1500 1991-1988



P/N: B515004 REPLACE: 515004
 Brand Model Year
 FORD EXPEDITION 2000-1997
 LINCOLN NAVIGATOR 2000-1998



P/N: B515006 REPLACE: 515006
 Brand Model Year
 DODGE RAM1500 1999-1994



P/N: B515009 REPLACE: 515009
 Brand Model Year
 DODGE DAKOTA 2004-1997
 DURANGO 2003-1998

U-Joint With 4 Plain Round Bearings And 4 Grooved Round Bearings

FIG	PART NO	D	O	L	SPICER	PRECISION	GMB	GKN
A	5-263X	34.93	—	106.31	5-263X	351	G5-263X	—
B	5-273X	27	67.6	—	5-273X	433	G5-273X	—
A	5-275X	34.93	—	126.22	5-275X	358	G5-275X	HS275
B	5-297X	30.2	52.5	—	5-297X	371	G5-297X	HS457
B	5-297X-1	30.2	52.5	—	5-297X-1	377	G5-297X-1	HS457
B	5-3147X	28.6	60.2	—	5-3147X	534G	GU6370	HS451
A	5-325X	34.93	—	126.22	5-325X	358	G5-325X	HS275
A	5-4X	27.01	—	74.6	5-4X	344	GU1100	HS195
A	5-443X	27.01	—	61.95	5-443X	437	G5-443X	—
B	5-456X	27	38.38	—	5-456X	436	G5-456X	—
B	5-521X	27	67.6	—	5-521X	433	G5-521X	—
B	5-74X	27	52.4	—	5-74X	356	G5-74X	HS441
B	5-92X	24.6	32.56	—	5-92X	982	G5-1004	—
A	K5GB10R	30.16	—	106.35	—	—	—	—
A	K5-13XR	26.99	—	81.76	—	—	—	—
B	K5LGB80R	23.81	61.60	—	—	—	—	HS194

Japanese Car Universal Joint

NISSAN

PART NO	D	O	L	ORIGINAL NO	GMB	KOYO	MATSUBA
GUN26	23.82	—	61.3	37125-11975	GUN26	N2461	UJ110
GUN27	25	40	—	37125-14627	GUN27	N2563	UJ111
GUN28	20.01	35	—	37125-18025	GUN28	N2057	—
GUN29	28	53	—	37125-21025	GUN29	N2880BA	UJ112
GUN31	32	—	107	37125-50001	GUN31	N32111	UJ114
GUN41	43	—	135.5	37125-90128	GUN41	ND43142	UJ120
GUN43	55.1	—	163.8	37125-90027	GUN43	ND43128B	UJ125
GUN44	20.5	—	56.6	48155-99000	GUN44	—	UJ118
GUN46	27	46	—	37126-01G25	GUN46	—	UJ124
GUN47	27	—	81.75	37125-25025	GUN47	—	—
GUN48	27	—	81.75	37125-7F025	GUN48	—	—

TOYOTA

PART NO	D	O	L	ORIGINAL NO	GMB	KOYO	MATSUBA
GUT-11	20	—	57	04371-10011	GUT11	T2057	UJ212
GUT-12	26	53.6	—	04371-30011	GUT12	T2680C	UJ210
GUT-13	26	42	—	04371-20010	GUT13	T2667A	UJ211(221)(231)
GUT-14	28.5	—	77.9	04371-60010	GUT14	T2978	UJ214
GUT-16	39.98	—	111	04371-55020	GUT16	T40119	UJ215
GUT-17	29	49	—	04371-30020	GUT17	T2977	UJ230
GUT-19	20	—	57	04371-10010	GUT19	T2057	UJ222
GUT-20	32	61	—	04371-36021	GUT20	T32921	UJ234
GUT-21	29	49	—	04371-35020	GUT21	—	—
GUT-23	29	49	—	04371-35050	GUT23	—	—

MITSUBISHI

PART NO	D	O	L	ORIGINAL NO	GMB	KOYO	MATSUBA
GUM71	44	—	129	14501-27000	GUM71	M44135	UJ610
GUM73	27	—	81.75	GPW18397	GUM73	S2782	UJ620
GUM80	46	—	142	12018-01110	GUM80	M46142	UJ612
GUM83	52	—	153.8	12019-10000	GUM83	—	UJ626
GUM90	46	—	148	14801-06001	GUM90	—	UJ629

ISUZU

PART NO	D	O	L	ORIGINAL NO	GMB	KOYO	MATSUBA
GUIS51	23.82	—	61.3	9-37300-017	GUIS51	12461	UJ313
GUIS52	29	50	—	9-37300-065	GUIS52	12976	UJ314(324)
GUIS56	23.82	—	61.3	9-37300-609	GUIS56	—	—
GUIS59	20.5	—	56.6	44135-060	GUIS59	—	UJ315
GUIS60	49.2	—	148.38	9-37300-139-0	GUIS60	070004AR-1	UJ339
GUIS61	23.82	—	61.3	9-37300-031	GUIS61	—	—
GUIS65	45.98	—	136	1-37300-004-0	GUIS65	—	—
GUIS66	33	—	93	5-37300-032-0	GUIS66	—	UJ325
GUIS67	56	—	173.9	1-37300-049-0	GUIS67	—	—

HINO

PART NO	D	O	L	ORIGINAL NO	GMB	KOYO	MATSUBA
GUH72	47	—	144	37401-1080	GUH72	—	—
GUH73	50	—	165	37401-1021	GUH73	—	—

DALHATSU

PART NO	D	O	L	ORIGINAL NO	GMB	KOYO	MATSUBA
GUD81	20	—	55	4141-4120	GUD81	—	UJ218
GUD88	22.5	34.9	—	04371-87503	GUD88	—	—

SUZUKI

PART NO	D	O	L	ORIGINAL NO	GMB	KOYO	MATSUBA
GUS1	25	40.4	—	27200-58833	GUS1	SZ2564TR	UJ700
GUS2	20.01	35	—	27100-67000	GUS2	—	—
GUS6	20.07	—	59.8	27200-60511	GUS6	—	—
GUS7	25	—	63.9	27200-83810	GUS7	—	UJ413

MAZDA

PART NO	D	O	L	ORIGINAL NO	GMB	KOYO	MATSUBA
GUMZ-3	32	—	57	0164-25-060	GUMZ3(4)	TM3293	UJ414
GUMZ-7	25	41.2	—	0259-25-060	GUMZ-7	TM2564B	UJ413
GUMZ-8	37	67	—	0727-25-060	GUMZ-8	TM37104	UJ416
GUMZ-9	26.5	48	—	1757-89-251	GUMZ-9	—	UJ417

Brake Drum

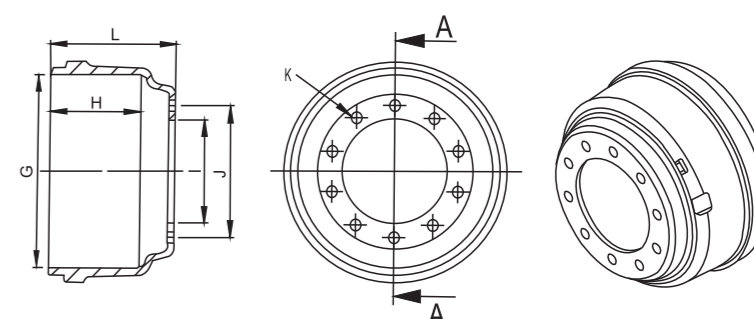

Item No.	Brake Drum	Application	Item No.	Brake Drum	Application
DR60301	60876	WEBB	DR60312	3600A	GUNITE
DR60302	62200	WEBB	DR60313	555-01163	KIC
DR60303	66250	WEBB	DR60314	555-01169	KIC
DR60304	66864	WEBB	DR60315	555-16729	KIC
DR60305	66884	WEBB	DR60316	AV-0002-001	KIC
DR60306	66892	WEBB	DR60317	AY-M1210205	KIC
DR60307	66893	WEBB	DR60318	555-66879	KIC
DR60308	66895	WEBB	DR60319	555-16325	KIC
DR60309	68730	WEBB	DR60320	51961-10	KIC
DR60310	67518	WEBB	DR60321	52890-13	KIC
DR60311	68765	WEBB	DR60322	52647-11	KIC

Brake Shoe /Lined Shoe Kit



Item No.	Fmsi No.	Application	Std PK	Item No.	Fmsi No.	Application	Std PK
BS84515E	4515Q	Meritor 16-1/2×7 "Q"	100	BS84702	4702Q	Meritor 15×4"Q-Plus"	200
BS84515Q	4515P	Meritor 16-1/2×7 "Q"	100	BS84311	4311E	Eaton 16-1/2×7	100
BS84515Q + WASHER	4515P + WASHER	Meritor 16-1/2×7 "Q"	100	BS84707	4707Q	Meritor 16-1/2×7 "Q-Plus"	100
BS84515X3	4515XEM3	Fruehauf 16-1/2×7	100	BS81443	1443E	Eaton 15×4"ES"	200
BS84515	4515X	Fruehauf 16-1/2×7	100	BS84551E	4551Q	—	100
BS81308E	1308E	Eaton 15×4	200	BS84551Q	4551P	—	100
BS81308D	1308P	Meritor 15×4"Q"	200	BS84524	4524Q	Meritor 16-1/2×5"Q"	200
BS81308Q	1308Q	Meritor 15×4"Q"	200	BS84591	4591SF	—	100
BS84709	4709E	Eaton 16-1/2×7 "ES-II"	100	—	—	—	—

Brake Repair Kit

Application & Cross Reference

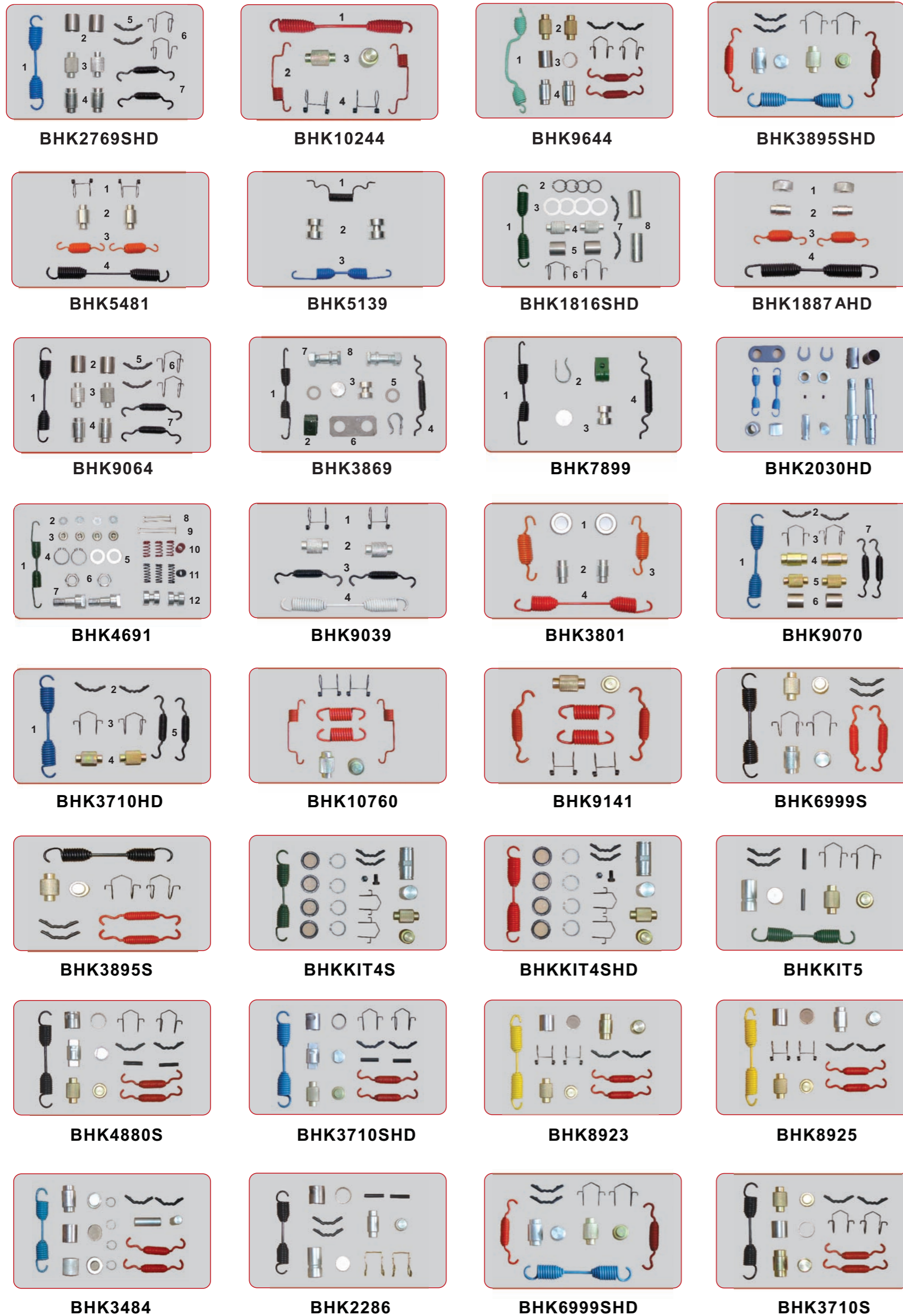

MBA No.	Replace Euclid	Replace Sirco	Replace Bwp	Replace Batco	MBA No.	Replace Euclid	Replace Sirco	Replace Bwp	Replace Batco
BHK10244	E-10244	ES-2	M-K105	08-1149	BHK2402HD	E-2402HD	LB-1	M-K12	08-1074
BHK10679	E-10679	—	M-K110	08-107303	BHK2403HD	E-2403HD	—	M-K43	08-1075
BHK10756	E-10756	LB-10	M-K108	08-104900	BHK2675HD	E-2675HD	MK-1HD	M-K54	08-1083
BHK10757	E-10757	LB-11	M-K109	08-105000	BHK2676	E-2676	—	M-K55	08-1081
BHK10760	E-10760	EF-2	M-K113	08-114920	BHK2713	E-2713	—	M-K51	08-1084
BHK10841	E-10841	BK-145F	—	—	BHK2740	E-2740	—	M-K49	08-1102
BHK10870	E-10870	BK-145R	—	—	BHK2769SHD	E-2769SHD	QK-1HD	M-K39 / M-K72	08-1088
BHK10875	E-10875	LB-3D	M-K112	08-104700	BHK2821	E-2821	EK-2	M-K58	08-1096
BHK1607HD	E-1607HD	TK-7HD	M-K56	08-1082	BHK3291	E-3291	WF-1	M-K50	08-1099
BHK1812	E-1812	—	M-K44	08-1072	BHK3373HD	E-3373HD	LB-2	—	—
BHK1816SHD	E-1816SHD	TK-4HD	M-K2 / M-K7	08-1003	BHK3484	E-3484	LB-3	M-K45	08-1093
BHK1887ASHD	E-1887ASHD	—	M-K10	08-1042	BHK3518	E-3518	RK-1	M-K59	08-1098
BHK1887AHD	E-1887AHD	EK-1HD	M-K99	—	BHK3710HD	E-3710HD	XK-3MPHD	—	—
BHK2030HD	E-2030HD	—	M-K11	08-1073	BHK3710S	E-3710S	XK-3	—	—
BHK2121	E-2121	FK-1	M-K8	08-1006	BHK3710SHD	E-3710SHD	XK-3HD	M-K42	08-1091
BHK2126	E-2126	LB-4	M-K46	08-1076	BHK3782	E-3782	LB-6	M-K83	—
BHK2286	E-2286	LB-5	M-K47	08-1077	BHK3801	E-3801	EK-3	M-K6	—
BHK3858	E-3858	MF-1	M-K92	—	BHK7231	E-7231	FF-1	M-K94	08-1140
BHK3869	E-3869	RF-3	M-K79	08-1111	BHK7237	E-7237	FR-1	M-K95	08-1142
BHK3895S	E-3895S	QK-2S	—	—	BHK7238	E-7238	FR-1S	—	—
BHK3895SHD	E-3895SHD	QK-2HD	—	—	BHK7899	E-7899	RF-3A	M-K79-B	08-1112
BHK3992	E-3992	RK-2	—	08-1098	BHK8923	E-8923	EX-1	—	—
BHK4691	E-4691	RF-1ARK	M-K52	08-1107	BHK8925	E-8925	EQ-1	—	—
BHK4692	E-4692	—	M-K53	08-1109	BHK9039	E-9039	ES-4	M-K115	08-104330
BHK4880S	E-4880S	XK-1	—	—	BHK9064	E-9064	RF-5	M-K98	08-1160
BHK4880SHD	E-4880SHD	XK-1HD	M-K41	08-1090	BHK9070	E-9070	MF-3	—	—
BHK5086	E-5086	MK-2	M-K93	08-1115	BHK9141	E-9141	ES-3	M-K114	08-104300
BHK5139	E-5139	EF-1	M-K77	08-1113	BHK9281	E-9281	LB-9	M-K80	—
BHK5306	E-5306	LB-7	M-K104	08-1051	BHK9283	E-9283	LB-8	—	—
BHK5481A	E-5481A	ES-1	M-K84	08-1148	BHK9644	E-9644	MF-2	M-K106	08-111635
BHK5515	E-5515	XL-1	M-K91	08-1162	BHKIT4S	KIT 4S	TK-1	M-K3	08-1417
BHK6999S	E-6999S	QK-8A	—	—	BHKIT4SHD	KIT 4SHD	TK-1HD	M-K4	08-1001
BHK6999SHD	E-6999SHD	QK-1A	—	—	BHKIT5	KIT 5	FK-2	M-K5	08-1005

Center Support Bearing

For American Applications

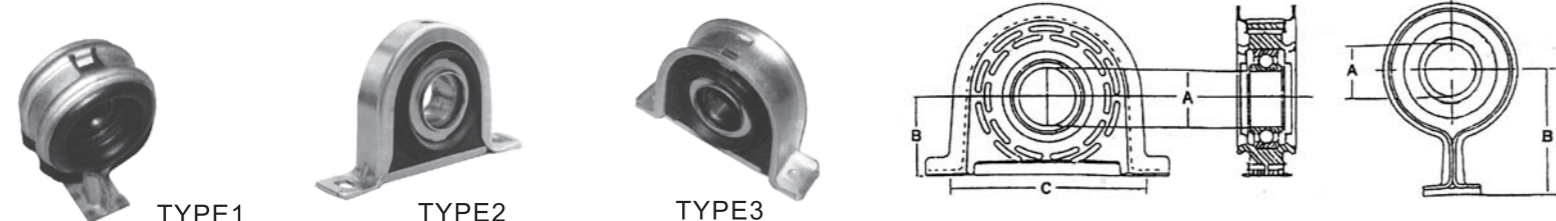

1. With reinforced frames.
2. Cold-rolled steel, powder coated.
3. 96 hours salt spray test.
4. Double lips land riding seals bearing to prevent water go inside.
5. 80% greased filled as barrier between dust shields bearing.

P/N	Type	Bore A		B		C		Slings Supplied	Bearing Only
		inches	mm	inches	mm	inches	mm		
HB206FF	1	1.1811	30	3.5	88.9	—	—	—	6206-2RS
HB88107A	2	1.3780	35	2 1/4	57.15	6 5/8	168.28	—	88107
HB88107B	2	1.3780	35	2 1/4	57.15	6 5/8	168.28	230118 230121	88107
HB88107C	2	1.3780	35	2 1/4	57.15	6 5/8	168.28	230118(2)	88107
HB88107D	2	1.3780	35	2 1/4	57.15	6 5/8	168.28	230141 98-1473(2)	88107
HB88107E	2	1.3780	35	2 1/4	57.15	6 5/8	168.28	230141 230104 98-1473	88107
HB88508	3	1.5748	40	2 1/2	63.5	6 5/8	168.28	—	88508
HB88508B	3	1.5748	40	2 1/2	63.5	6 5/8	168.28	230124 230209	88508
HB88508C	3	1.5748	40	2 1/2	63.5	6 5/8	168.28	230207 230208	88508
HB88508D	3	1.5748	40	2 1/2	63.5	6 5/8	168.28	230207(2) 230208	88508
HB88508E	3	1.5748	40	2 1/2	63.5	6 5/8	168.28	230124(2)	88508
HB88508A	2	1.5748	40	2 1/4	57.15	6 5/8	168.28	—	88508A
HB88508AA	2	1.5748	40	2 1/4	57.15	6 5/8	168.28	231004(2)	88508A
HB88508AB	2	1.5748	40	2 1/4	57.15	6 5/8	168.28	231004 231000	88508A
HB88509	3	1.7717	45	2 23/32	69.1	7 5/8	193.68	—	88509
HB88509A	3	1.7717	45	2 23/32	69.1	7 5/8	193.68	230151(2)	88509
HB88509B	3	1.7717	45	2 23/32	69.1	7 5/8	193.68	230151(2) 230363	88509
HB88509C	3	1.7717	45	2 23/32	69.1	7 5/8	193.68	230151 230363	88509
HB88510	3	1.9685	50	2 13/16	71.44	7 5/8	193.68	—	88510
HB88510S	3	1.9685	50	2 13/16	71.44	7 5/8	193.68	230166(2)	88510
HB88512	3	2.3622	60	3 3/8	85.73	8 5/8	219.08	—	88512
HB88512A	3	2.3622	60	3 3/8	85.73	8 5/8	219.08	230746(2)	88512

Bearing Slinger

Slinger Number	Type	Bore	Outside Diameter	Width
		A	B	C
230104	1	1.3740	2.5620	.7500
230118	2	2.0570	4.0000	.5620
230121	1	1.3740	2.4370	.6250
230124	2	2.3060	4.3750	.5620
230141	2	1.7570	4.0000	.8280
230151	2	2.5560	4.5620	.5620
230166	2	2.8070	4.8120	.5620
230207	2	2.5250	4.3750	.8750
230208	1	1.5690	2.8750	.9380
230209	1	1.5690	2.6250	.5940
230363	1	1.7650	2.8750	.5940
230746	2	3.3120	5.5620	.5780
231000	1	1.5690	2.4370	.6410
231004	2	2.1490	4.0000	.5620
98-1473	3	1.7470	2.5000	.5000

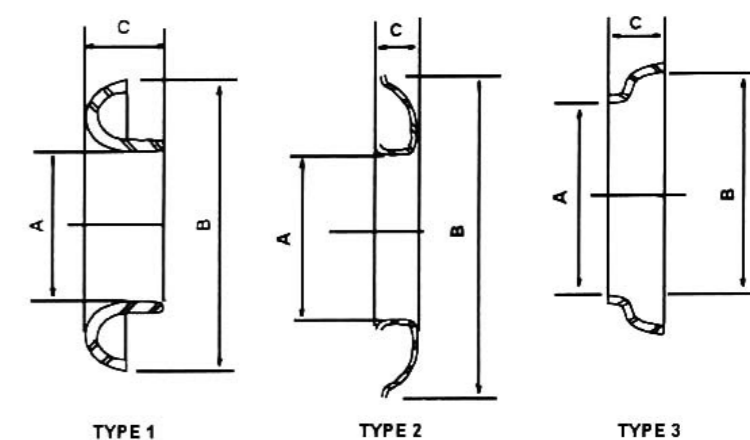

For European Application

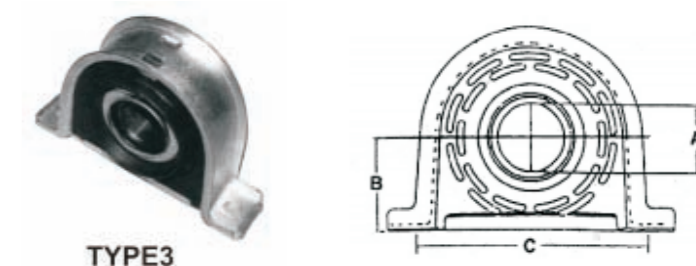

Part NO.	Type	Boundary Dimension						Bearing No.	Slinger
		A		B		C			
		mm	inch	mm	inch	mm	inch		
HB35	3	35	1.3780	57.2	2-1/4	168.2	6-5/8	6207-2RS	yes
HB45	3	45	1.7717	69	2-23/32	193.6	7-5/8	6209-2RS	yes
HB50	3	50	1.9685	71.4	2-13/16	193.6	7-5/8	6210-2RS	yes
HB60212	3	60	2.3622	85.7	3-3/8	219	8-5/8	6212-2RS	yes
HB60512	3	60	2.3622	85.7	3-3/8	219	8-5/8	88512	yes
HB60512S	3	60	2.3622	85.7	3-3/8	219	8-5/8	88512	yes



For Japanese Car



PART No.	FOR WHICH CAR	PART No.	FOR WHICH CAR
37207-35011	Toyota Hilux Rn20	37518-90009/Z5002	Nissan Truck CW30, Ug780
37230-35013	Toyota Hilux RN15,16,20	37518-90010	Nissan Truck TW
	Toyota Hilux RK101,111	8-94204-521-0	Isuzu Pick-Up KB20
37230-35030	Toyota Hilux RN30	8-94202-521-0/8-94222-970-0	Isuzu Pick-Up KBZ
	Toyota Hilux LN40,41		Isuzu Pick-Up KB21, 26, 41
37230-35040/41	Toyota Stout RK110; YK110	8-94328-800-0	Isuzu Pick-Up TER(4JA1)
37230-35050/70	Toyota Hilux LN55,56,57,58,85	5-37516-030-0	Isuzu Truck ELF250
	Toyota Hilux LN50,55,56,85	5-37516-006-1	Isuzu Truck Super ELF
37230-35060/61	Toyota Hilux YN65,67; LN65	5-37516-005-1	Isuzu Truck KS22
37230-35070	Toyota Hilux YN56; Mighty-X	1-37510-105-0	Isuzu Truck JCR, SBR
37230-35080	Toyota Hilux LN106; YN106	1-37516-043-0	Isuzu Truck Rocky 175 HP
	Toyota Land Cruiser	1-37510-092-3	Isuzu Truck Rocky 210 HP
37230-40031	Toyota Hilux RN25, LN25	1-37516-043-1	Isuzu Truck Rocky 240 HP
37230-30022	Toyota Crown MS100,107	9-37516-031-0	Isuzu Truck TXD 68

For Japanese Car

PART No.	FOR WHICH CAR	PART No.	FOR WHICH CAR
37230-40031	Toyota Crown RS100,102 LS100	1-37516-006-1	Isuzu Truck JCM
37230-30022	Toyota Crown RS110, GS110	9-37516-008-0	Isuzu Bus 200 HP
	Toyota Crown MS111,117	9-37516-045-1	Isuzu Bus 260 HP
37230-30030	Toyota Crown LS111,117	-----	Isuzu Truck JCZ
	Toyota Crown YS120; MS122(4F,5F)	-----	Isuzu Truck FXZ
	Toyota Dyna Bu10, 15, 19 Ju18	Mb154080	Mitsubishi Pick-Up L200(Diesel)
	Toyota Dyna RU20,30		(L021, L025)
37230-30040	Toyota Dyna RU30,HU30	MB000815/154199\	Mitsubishi Pick-Up L200(Benzil)
37230-36014	Toyota Dyna BU45, 61, Ru30		(L021-4WD-)
37230-36020/	Toyota Dyna BU40, 50	Mb000083	Mitsubishi Canter 4D30, FE111,211
36021/36H00	Toyota Corolla KE70, 71 TE70,71		FC111, 211
37230-36060/36061	Toyota Corolla AE86, CE80	MT119504	Mitsubishi Canter T210(4DR5)
37230-36070/36071	Toyota Cressida 76' , Chas, Cresta	12019-28000/ME031962	Mitsubishi Fuso Truck FM215
37230-12040	Toyota Corona MARK II	MC802792	Mitsubishi Fuso Truck FM527
37230-12050	Toyota Corona RT141, CT140	-----	Mitsubishi Fuso Truck FM227, FL
37230-22042	Toyota Craina TA61, RA63	0755-25-300D	Mazda Pick-Up B1600(NA)
	Toyota Celica TA60, GA61B		Mazda Familia, Proceed
37230-24010/20	Toyota Truck Da115	P030-25-310C	Mazda Pick-Up B2200, Magnum
	Daihatsu Delta V12,22,V32	P047-25-310A	Mazda Pick-Up Thunder (B2500DI)
	Datsun Pick-Up620(J15)	0672-25-321	Mazda Truck E2700
37235-55020	Datsun Pick-Up720	W001-25-321	Mazda Truck T3000
37208-87302-000	(J15, J16, L18, SD22)	37404-1060	Hino Truck KR, BX
37521-B5000/5001	Datsun Big M, Skyline	37235-1100/1110/1190	Hino Truck KM, KC, KQ
37521-B9500/5025	Datsun Bluebird,Laurel	37235-1130/2445-3436-21	Hino Truck KR, KL500; FD
37521-01W00/01W25	Datsun Cedric, Gloria 430	2305-3422-00/37404-1190	Hino Truck KT725
	Datsun Sunny B110,310, Bluebird	37235-1171	Hino Truck BX
37521-Q0125/W1025	Datsun Laurel, Violet, Cedric	37235-1080A/37404-1190	Hino Truck KT920
	Datsun Bluebird 910	2301-3410-02	Hino Truck ZM, TC
	Datsun Pick-Up D21-4WD-	37404-1110	Hino Truck KM, KL
37521-P0125/0126/0110	Nissan Caball, Junior		Hino Truck FM227
37521-A0100/0101/Y0125	Nissan Condor H40		
37522-W1000			
37521-32G25/33G25/56G25			
37521-J2100/5125/69800			

Clutch Release Bearing

			
P/N: CRB500117211 REPLACE: "Luk 500117211" "INA F-210152"	P/N: CRB500032010 REPLACE: "Luk 500032010"	P/N: CRB500044010 REPLACE: "Luk 500044010" "INA F-217376"	P/N: CRB500090120 REPLACE: "Luk 500090120" "INA FC 67430"
			
P/N: CRB500044510 REPLACE: "Luk 500044510"	P/N: CRB500075810 REPLACE: "Luk 500075810" "INA F-123536"	P/N: CRB500076610 REPLACE: "Luk 500076610" "INA F-557607"	P/N: CRB500117210 REPLACE: "Luk 500117210"

HYDRAULIC CLUTCH RELEASE BEARING

				
MBA NO:HCRB510005010 GENERAL MOTORS :12574147 LUK NO:510005010	MBA NO:HCRB510003710 GENERAL MOTORS :15046288 LUK NO:510003710	MBA NO:HCRB510004610 FORD MOTOR:F75Z-7A508-AA LUK NO:510004610	MBA NO:HCRB510004510 BENDIX:12593 LUK NO:510004510	MBA NO:HCRB510005910 FORD MOTOR:YL5Z-7A508-AA FORD MOTOR:6L5Z 7A508-AA LUK NO:510005910
				
MBA NO:HCRB510001110 FORD MOTOR:XS417A564EA FORD MOTOR:96WT7A564BA LUK NO:510001110	MBA NO:HCRB510007310A SAAB:24422061 VAUXHALL:90470874 SACHS:3182998803 LUK NO:510007310	MBA NO:HCRB510006910 LUK NO:510006910	MBA NO:HCRB510007310 SAAB:24422061 VAUXHALL:90470874 ALFA ROMEO:71747899 OPEL:5679335 LUK NO:510007310	MBA NO:HCRB510004110 GENERAL MOTORS :15018532 BENDIX:13207-SC-360058 LUK NO:510004110

				
MBA NO:HCRB510001310 LUK NO:510001310	MBA NO:HCRB510007010 GENERAL MOTORS:22638960 BENDIR:13560 LUK NO:510007010	MBA NO:HCRB510000210 VAUXHALL:90522729 OPEL:90522729 LUK NO:510000210	MBA NO:HCRB5100019100 JOHN DEERE:AZ 36461 SPERRY NEW HOLLAND: 82005471 LUK NO:5100019100	MBA NO:HCRB510003610 MERCEDES-BENZ : A0002541308 LUK NO:510003610
				
MBA NO:HCRB510003510 MERCEDES-BENZ :A0002542508 CHRYSLER:5114332AA LUK NO:510003510	MBA NO:HCRB510000710 FORD MOTOR:94ZT-7A564-BA FORD MOTOR:7113401 LUK NO:510000710	MBA NO:HCRB5100011110 NISSAN:32150-00QAD NISSAN:32150-00QAB LUK NO:510011110	MBA NO:HCRB510009010 RENAULT:8200855816 RENAULT:8200046102 LUK NO:510009010	MBA NO:HCRB510009710 NISSAN:30620-BN700/30620-00QOE RENAULT:8200046103/8 00764613 LUK NO:510009710
				
MBA NO:HCRB510006510 FORD MOTOR:1477989 FORD MOTOR:2S617A564AC LUK NO:510006510	MBA NO:HCRB510006310 SAAB:24424546 VAUXHALL:90523765 OPEL:5679333 LUK NO:510006310	MBA NO:HCRB510000110 FORD MOTOR: 94ZT-7A564-AA /7113400 SEAT:0061411165C LUK NO:510000110	MBA NO:HCRB510002511 NISSAN:30570-00Q0D/30570-00Q0F OPEL:4413842/4416385/4432435 RENAULT:8200609202 VAUXHALL :93161282 LUK NO:510002511	MBA NO:HCRB510002310 FORD MOTOR:1141581 FORD MOTOR:XS417A564AC LUK NO:510002310
				
MBA NO:HCRB510005120 GENERAL MOTORS:2262257 HOLDEN:22602575 OPEL:22602575 LUK NO:510 005120	MBA NO:HCRB510007410 FORD MOTOR:1512917 FORD MOTOR:4C11-7C559-AB LUK NO:510007410	MBA NO:HCRB510005420 MERCEDES-BENZ:0022502215 LUK NO:510005420	MBA NO:HCRB510009210 FORD MOTOR:4C11-7C559-AB FORD MOTOR:4543504/1512917 LUK NO:510009210	MBA NO:HCRB510001610 GENERAL MOTORS:4416385/93813379 NISSAN:30570-00Q0C/30570-00Q0F RENAULT:8200785483 LUK NO:510001610
	MBA NO:HCRB510001530 LUK NO:510001530			

Camshaft

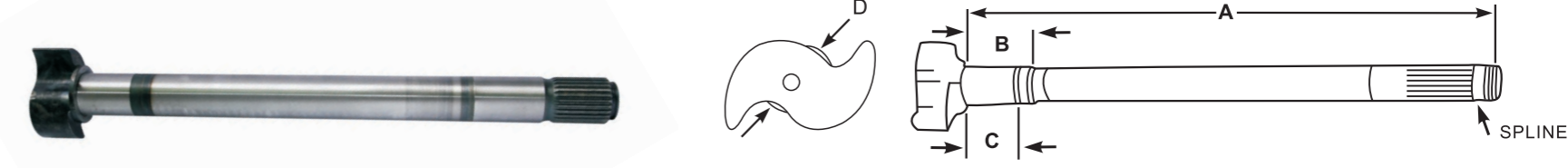

MBA	Euc Cross	Hm Cross	Batco Cross	Bwp Cross	Pdc Cross	Application	Spline	Shaft Length (A)	Shaft Length (B)	Shaft Length (C)	Cam (D)
CAM-103534429245L	E-1147B&C	Cs41017	04-451151	M743L	1147CP	Meritor 16 1/2"Q+	1 1/2"-10	11 1/2"	—	1 3/4"	1 3/8"
CAM-103534429245R	E-1148B&C	CS41016	04-451152	M743R	1148CP	Meritor 16 1/2"Q+	1 1/2"-10	11 1/2"	—	1 3/4"	1 3/8"
CAM-103556951745L	E1424A	—	—	M562-L	—	—	1 1/2"-10	20 3/8"	2 7/32"	1 5/8"	1 3/8"
CAM-103556951745R	E1425A	—	—	M562-R	—	—	1 1/2"-10	20 3/8"	2 7/32"	1 5/8"	1 3/8"
CAM-103564759545L	E1095	—	—	M744-L	—	—	1 1/2"-10	23 7/16"	—	2 7/32"	1 3/8"
CAM-103564759545R	E1094	—	—	M744-R	—	—	1 1/2"-10	23 7/16"	—	2 7/32"	1 3/8"
CAM-282863458245L	E3856	CS41164	04-582352	M3188L	3856P	Spicer 16 1/2"	1 1/2"-28	22 15/16"	2 7/32"	1 5/8"	1 1/8"
CAM-282863458245R	E3857	CS41165	04-582351	M3188R	3857P	Spicer 16 1/2"	1 1/2"-28	22 15/16"	2 7/32"	1 5/8"	1 1/8"

MBA	Euc Cross	Hm Cross	Batco Cross	Bwp Cross	Pdc Cross	Application	Spline	Shaft Length (A)	Shaft Length (B)	Shaft Length (C)	Cam (D)
CAM-282866461245L	E10909	—	—	M3699L	—	—	1 1/2"-28	24 1/8"	—	2 7/32"	1 1/8"
CAM-282866461245R	E10910	—	—	M3699R	—	—	1 1/2"-28	24 1/8"	—	2 7/32"	1 1/8"
CAM-283026921745L	E9649	CS41074	04-480862	M3109L	9649P	Meritor 16 1/2"Q+	1 1/2"-28	8 9/16"	—	1 3/4"	1 3/16"
CAM-283026921745R	E9650	CS41075	04-480861	M3109R	9650P	Meritor 16 1/2"Q+	1 1/2"-28	8 9/16"	—	1 3/4"	1 3/16"
CAM-283033628445L	E9659	CS41082	04-481122	M3111L	9659P	Meritor 16 1/2"Q+	1 1/2"-28	11 3/16"	—	1 3/4"	1 3/16"
CAM-283033628445R	E9660	CS41083	04-481121	M3111R	9660P	Meritor 16 1/2"Q+	1 1/2"-28	11 3/16"	—	1 3/4"	1 3/16"
CAM-283034329145L	E9661	CS41084	04-481152	M3112L	9661P	Meritor 16 1/2"Q+	1 1/2"-28	11 15/32"	—	1 3/4"	1 3/16"
CAM-283034329145R	E9662	CS41085	04-481151	M3112R	9662P	Meritor 16 1/2"Q+	1 1/2"-28	11 15/32"	—	1 3/4"	1 3/16"
CAM-283038533345L	E9671	CS41086	04-481332	M3114L	9671P	Meritor 16 1/2"Q+	1 1/2"-28	13 1/8"	—	1 3/4"	1 3/16"
CAM-283038533345R	E9672	CS41087	04-481331	M3114R	9672P	Meritor 16 1/2"Q+	1 1/2"-28	13 1/8"	—	1 3/4"	1 3/16"
CAM-283066361145L	E5510	—	04-912422	M3172L	5510P	Meritor 16 1/2"Q+	1 1/2"-28	24 1/16"	2"	1 11/16"	1 3/16"
CAM-283066361145R	E5511	—	04-912421	M3172R	5511P	Meritor 16 1/2"Q+	1 1/2"-28	24 1/16"	2"	1 11/16"	1 3/16"
CAM-283549043845L	E2441A&B	CS41504	04-891731	M990L	2441BP	Meritor 16 1/2"Q+	1 1/2"-28	17 1/4"	2"	1 11/16"	1 3/8"
CAM-283549043845R	E2442A&B	CS41505	04-891732	M990R	2442BP	Meritor 16 1/2"Q+	1 1/2"-28	17 1/4"	2"	1 11/16"	1 3/8"
CAM-283556951745L	E3854	CS41053	04-582042	M3175L	3854P	Spicer 16 1/2"	1 1/2"-28	20 3/8"	2 7/32"	1 5/8"	1 3/8"
CAM-283556951745R	E3855	CS41052	04-582041	M3175R	3855P	Spicer 16 1/2"	1 1/2"-28	20 3/8"	2 7/32"	1 5/8"	1 3/8"
CAM-283556951745QL	E2443A&B	CS41112	04-892042	M991L	2443BP	Meritor 16 1/2"Q+	1 1/2"-28	20 3/8"	2"	1 11/16"	1 3/8"
CAM-283556951745QR	E2444A&B	CS41113	04-892041	M991R	2444BP	Meritor 16 1/2"Q+	1 1/2"-28	20 3/8"	2"	1 11/16"	1 3/8"
CAM-283566361145L	E2445A&B	CS41114	04-892422	M992L	2445BP	Meritor 16 1/2"Q+	1 1/2"-28	24 1/16"	2"	1 11/16"	1 3/8"
CAM-283566361145R	E2446A&B	CS41115	04-892421	M992R	2446BP	Meritor 16 1/2"Q+	1 1/2"-28	24 1/16"	2"	1 11/16"	1 3/8"
CAM-373546140945L	E1563	CS41529	04-811622	M563L	1563P	Fruehauf 16 1/2"	1 5/8"-37	16 1/8"	—	2 5/32"	1 3/8"
CAM-373546140945R	E1564A	CS41528	04-811621	M563R	1564P	Fruehauf 16 1/2"	1 5/8"-37	16 1/8"	—	2 5/32"	1 3/8"

Camshaft Repair Kit

Camshaft repair kits and applications

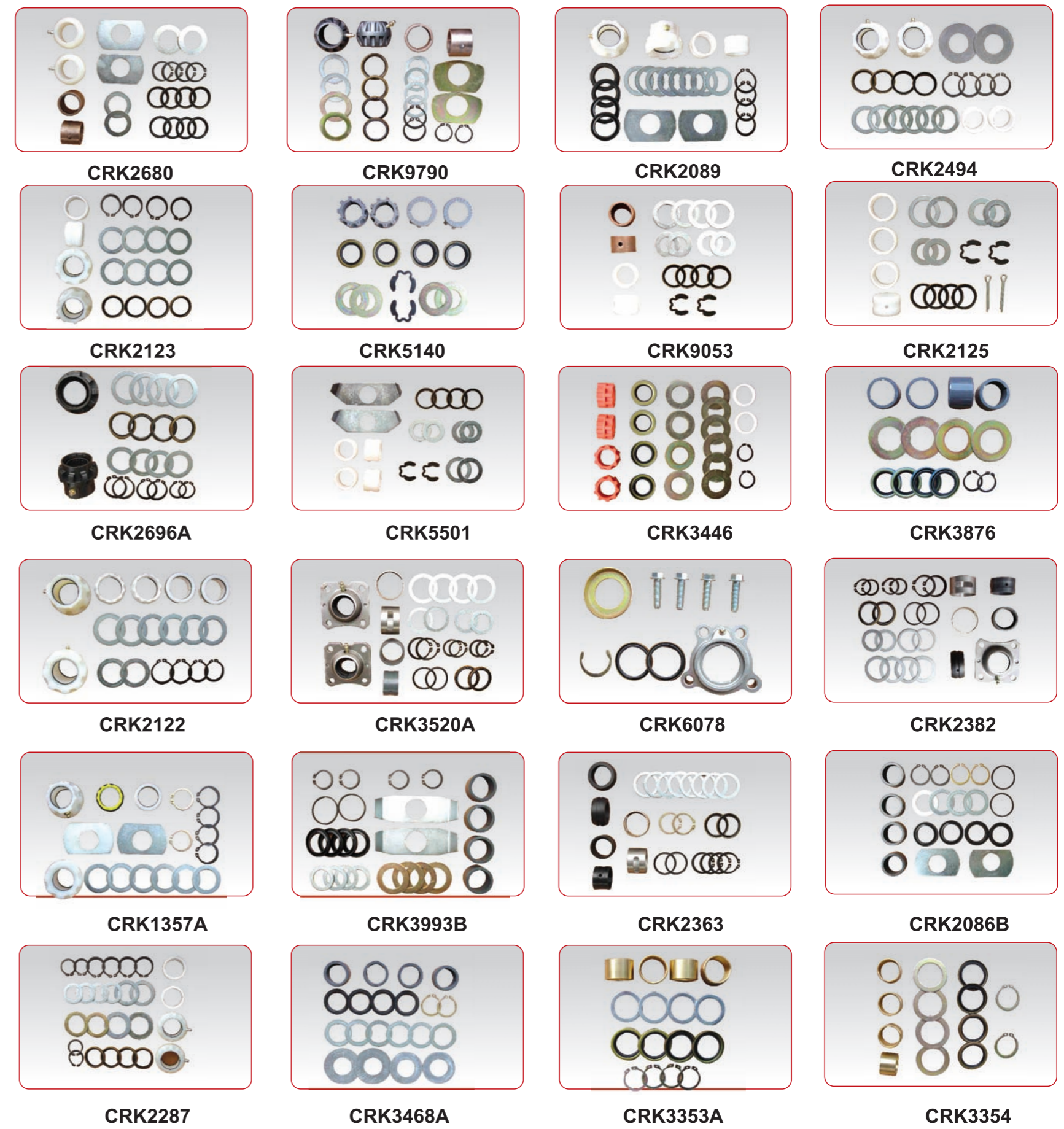
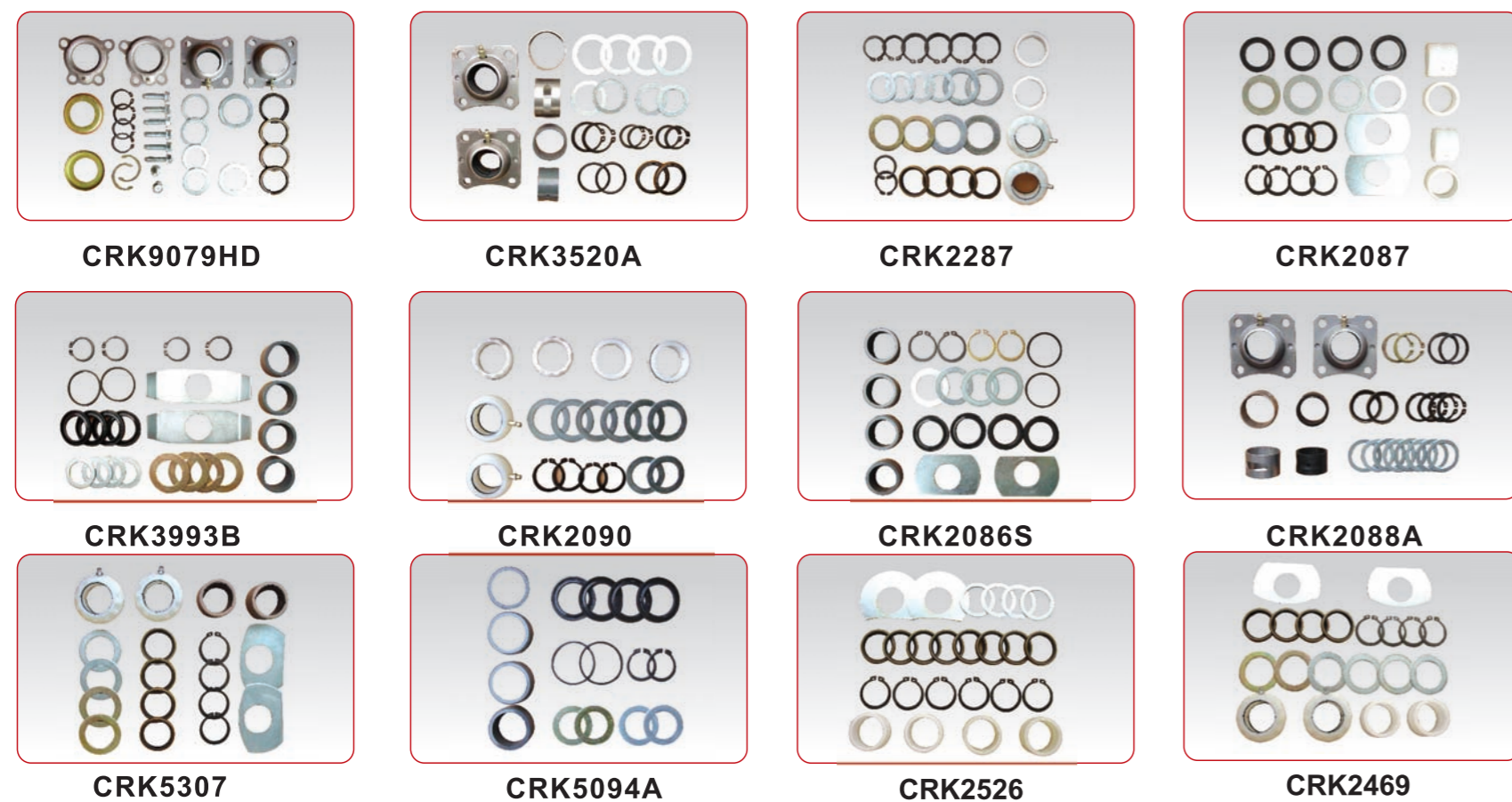

MBA No.	Replace Euclid No.	Replace Sirco No.	Replace BWP No.	Replace BATCO No.
CRK10948	E-10948	—	M-K111	08-132900
CRK1357A	E-1357A	B8643	M-K13	08-1300
CRK2086B	E-2086B	B8646	M-K17	08-1302
CRK2087	E-2087	B8656	M-K27	08-1324
CRK2088A	E-2088A	B8681	M-K14	08-1301
CRK2089	E-2089	B8657	M-K62	08-1308
CRK2090	E-2090	B8649	M-K20	08-1331
CRK2122	E-2122	B8650	M-K21	08-1330
CRK2123	E-2123	B8647	M-K18	08-1308
CRK2125	E-2125	B8648	M-K19	08-1351
CRK2287	E-2287	B8652	M-K24	08-1321
CRK2363	E-2363A	B8644	M-K15	08-1311
CRK2382	E-2382	B8645	M-K16	08-1306
CRK2469	E-2469	B8655	M-K26	08-1323
CRK2494	E-2494	B8712	M-K60	08-1366
CRK2526	E-2526	B8682	M-K25	08-1341
CRK2679A	E-2679A	B8686	M-K65	08-1305

MBA No.	Replace Euclid No.	Replace Sirco No.	Replace BWP No.	Replace BATCO No.
CRK2680	E-2680	B8685Z	M-K64	08-1325
CRK2696A	E-2696A	B8684	M-K63	08-1364
CRK2705	E-2705	—	M-K71	08-1363
CRK3353A	E-3353A	—	M-K66	08-1370
CRK3354	E-3354	—	M-K67	08-1371
CRK3446	E-3446	B8743	M-K68	08-1369
CRK3468A	E-3468A	RC-1	M-K69	08-1368
CRK3520A	E-3520A	B8683	M-K61	08-130601
CRK3876	E-3876	B8744	M-K87	08-1361
CRK3989	E-3989	B8747HD	M-K85	—
CRK3993B	E-3993B	B8707	M-K81	08-1318
CRK5140	E-5140	B8742	M-K78	08-1375
CRK5501	E-5501	B8746	M-K86	08-1352
CRK6078	E-6078	B8788	M-K90	—
CRK7235	E-7235	B8795	M-K96	08-1378
CRK7241	E-7241	B8796	M-K97	09-1379
CRK9053	E-9053	B8793	M-K116	08-135110
CRK9078	E-9078	B8772M	M-K89	—
CRK9079HD	E-9079HD	B8773MHD	M-K88	08-130611
CRK9790	E-9790A	B8792	M-K103	—
CRK9791	E-9791	B8790	M-K107	08-130301
CRK5307	E-5307	—	M-K102	08-132310
CRK5094A	—	—	—	08-137300

Cord



CORE21415



CORE27712



CORE27039



CORE27096

Electric Cord

MBA Item	Replace Phillips	A Series				B Series			
		Electric Cord specification	Metal plugs (pcs)	Length	Electric Cord diameter	Electric Cord specification	Metal plugs (pcs)	Length	Electric Cord diameter
CORE21412	23-4325	1pcs 4 gauge copper conductor	2	10'	0.3937"	1 pcs 7 gauge copper conductor	2	10'	0.3937"
CORE21415	23-4625	1pcs 4 gauge copper conductor	2	12'	0.3937"	1 pcs 7 gauge copper conductor	2	12'	0.3937"
CORE27029	22-9321	1pcs 10 gauge copper conductor 6pcs 12 gauge copper conductor	2	10'	0.7087"	1pcs 14 gauge copper conductor 6pcs 16 gauge copper conductor	2	10'	0.7087"
CORE27031	22-9621	1pcs 10 gauge copper conductor 6pcs 12 gauge copper conductor	2	12'	0.7087"	1pcs 14 gauge copper conductor 6pcs 16 gauge copper conductor	2	12'	0.7087"
CORE27039	22-4321	1pcs 10 gauge copper conductor 6pcs 12 gauge copper conductor	2	10'	0.7087"	1pcs 14 gauge copper conductor 6pcs 16 gauge copper conductor	2	10'	0.7087"
CORE27041	24-4621	1pcs 12gauge copper conductor 6pcs 14 gauge copper conductor	2	12'	0.5512"	7 pcs 17 gauge copper conductor	2	12'	0.4724"
CORE27076	22-9721	1pcs 10 gauge copper conductor 6pcs 12 gauge copper conductor	2	12'	0.7087"	1pcs 14 gauge copper conductor 6pcs 16 gauge copper conductor	2	12'	0.7087"

ABS Cord

MBA Item	Replace Phillips	A Series				B Series			
		Electric Cord specification	Metal plugs (pcs)	Length	Electric Cord diameter	Electric Cord specification	Metal plugs (pcs)	Length	Electric Cord diameter
CORABS27072	30-4921	1pcs 8 gauge copper conductor 2pcs 10 gauge copper conductor 4pcs 12 gauge copper conductor	2	12'	0.8268"	1pcs 12 gauge copper conductor 2pcs 14 gauge copper conductor 4pcs 16 gauge copper conductor	2	12'	0.8268"
CORABS27712	30-4321	1pcs 8 gauge copper conductor 2pcs 10 gauge copper conductor 4pcs 12 gauge copper conductor	2	10'	0.8268"	1pcs 12 gauge copper conductor 2pcs 14 gauge copper conductor 4pcs 16 gauge copper conductor	2	10'	0.8268"
CORABS27715	30-4621	1pcs 8 gauge copper conductor 2pcs 10 gauge copper conductor 4pcs 12 gauge copper conductor	2	12'	0.8268"	1pcs 12 gauge copper conductor 2pcs 14 gauge copper conductor 4pcs 16 gauge copper conductor	2	12'	0.8268"
CORABS27772	30-4921	1pcs 8 gauge copper conductor 2pcs 10 gauge copper conductor 4pcs 12 gauge copper conductor	2	12'	0.8268"	1pcs 12 gauge copper conductor 2pcs 14 gauge copper conductor 4pcs 16 gauge copper conductor	2	12'	0.8268"
CORABS27457	30-2051	1pcs 8 gauge copper conductor 2pcs 10 gauge copper conductor 4pcs 12 gauge copper conductor	2	10'	0.8268"	1pcs 12 gauge copper conductor 2pcs 14 gauge copper conductor 4pcs 16 gauge copper conductor	2	10'	0.8268"
CORABS27458	30-2071	1pcs 8 gauge copper conductor 2pcs 10 gauge copper conductor 4pcs 12 gauge copper conductor	2	12'	0.8268"	1pcs 12 gauge copper conductor 2pcs 14 gauge copper conductor 4pcs 16 gauge copper conductor	2	12'	0.8268"

Straight Cord

MBA Item	Replace Phillips	A Series				B Series			
		Electric Cord specification	Metal plugs (pcs)	Length	Electric Cord diameter	Electric Cord specification	Metal plugs (pcs)	Length	Electric Cord diameter
CORS27010	22-2031	1pcs 10 gauge copper conductor 6pcs 12 gauge copper conductor	2	8'	0.7087"	1pcs 14 gauge copper conductor 6pcs 16 gauge copper conductor	2	8'	0.7087"
CORS27012	22-2051	1pcs 10 gauge copper conductor 6pcs 12 gauge copper conductor	2	10'	0.7087"	1pcs 14 gauge copper conductor 6pcs 16 gauge copper conductor	2	10'	0.7087"
CORS27015	22-2071	1pcs 10 gauge copper conductor 6pcs 12 gauge copper conductor	2	12'	0.7087"	1pcs 14 gauge copper conductor 6pcs 16 gauge copper conductor	2	12'	0.7087"

ISO Cord

MBA Item	Replace Phillips	A Series				B Series			
		Electric Cord specification	Metal plugs (pcs)	Length	Electric Cord diameter	Electric Cord specification	Metal plugs (pcs)	Length	Electric Cord diameter
CORISO27091	31-2053	1pcs 8 gauge copper conductor 2pcs 10 gauge copper conductor 4pcs 12 gauge copper conductor	2	10'	0.8268"	1pcs 12 gauge copper conductor 2pcs 14 gauge copper conductor 4pcs 16 gauge copper conductor	2	10'	0.8268"

ISO Cord

MBA Item	Replace Phillips	A Series				B Series			
		Electric Cord specification	Metal plugs (pcs)	Length	Electric Cord diameter	Electric Cord specification	Metal plugs (pcs)	Length	Electric Cord diameter
CORISO27092	31-2073	1pcs 8 gauge copper conductor 2pcs 10 gauge copper conductor 4pcs 12 gauge copper conductor	2	12'	0.8268"	1pcs 12 gauge copper conductor 2pcs 14 gauge copper conductor 4pcs 16 gauge copper conductor	2	12'	0.8268"
CORISO27095	31-9323	1pcs 8 gauge copper conductor 2pcs 10 gauge copper conductor 4pcs 12 gauge copper conductor	2	10'	0.8268"	1pcs 12 gauge copper conductor 2pcs 14 gauge copper conductor 4pcs 16 gauge copper conductor	2	10'	0.8268"
CORISO27096	31-9623	1pcs 8 gauge copper conductor 2pcs 10 gauge copper conductor 4pcs 12 gauge copper conductor	2	12'	0.8268"	1pcs 12 gauge copper conductor 2pcs 14 gauge copper conductor 4pcs 16 gauge copper conductor	2	12'	0.8268"
CORISO27345	31-9923	1pcs 8 gauge copper conductor 2pcs 10 gauge copper conductor 4pcs 12 gauge copper conductor	2	12'	0.8268"	1pcs 12 gauge copper conductor 2pcs 14 gauge copper conductor 4pcs 16 gauge copper conductor	2	12'	0.8268"

Fifth Wheel

FEATURES

- UNIVERSAL INTERCHANGEABLE WEARABLE COLLAR+LOCKING ASSEMBLY
- COMPLIED WITH AUSTRALIAN STANDARD AS1773-1996
- DYNAMICALLY TESTED AND APPROVED TO AUSTRALIAN DESIGN RULES ADR 62/01
- FULLY PRESSED+FABRICATED WITH HIGH QUALITY STEEL PRODUCTS
- SUITABLE FOR SINGLE TRAILER, B DOUBLE AND TRIPLE ROADTRAINS APPLICATION

MODEL : FWHM78A-HIGHWAY MASTER

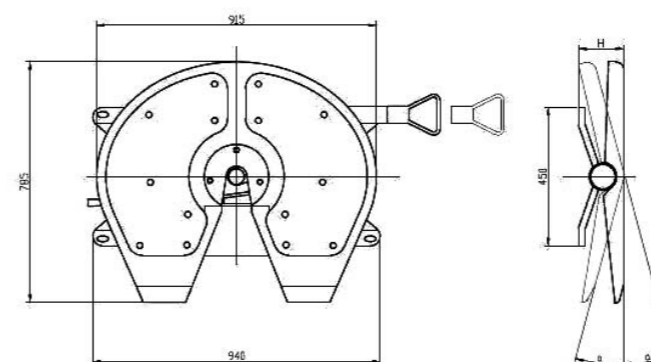

MODEL : FWHM78B-HIGHWAY MASTER

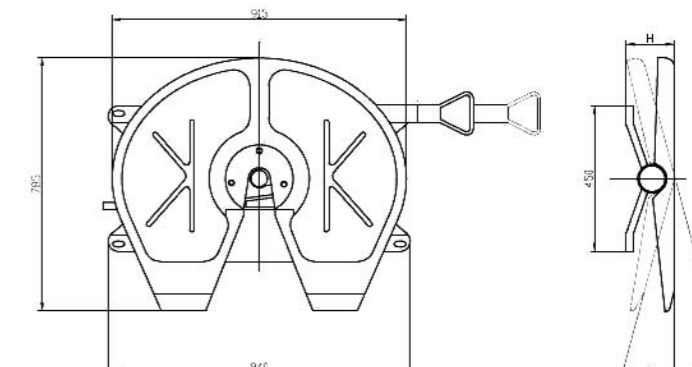

ITEM ID	INSTALL HEIGHT	VERTICAL LOAD	D-VALUE	VERTICAL SWING ANGLE	NET WEIGHT (KG)
FWHM78A1	172	20,000KG	152	15	128.9
FWHM78A2	150			13	127.9
FWHM78A3	185			18	129.9

ITEM ID	INSTALL HEIGHT	VERTICAL LOAD	D-VALUE	VERTICAL SWING ANGLE	NET WEIGHT (KG)
FWHM78B1	172	20,000KG	152	15	146
FWHM78B2	150			13	145
FWHM78B3	185			18	147

Conspicuity Tape

	Description	Width	Red	White	Yellow	Total Length
RW66-2	2" x 12" strip of 6" Red / 6" White Tape	2"	6"	6"		12"
RW117-2	2" x 18" strip of 11" Red / 7" White Tape	2"	11"	7"		18"
RW66-2X150	2" x 150' of 6" Red / 6" White Tape	2"	6"	6"		150'
RW117-2X150	2" x 150' of 11" Red / 7" White Tape	2"	11"	7"		150'
RW44-2X150	2" x 150' of 4" Red / 4" White Tape	2"	4"	4"		150'
R2X150	2" x 150' Red Reflective Tape	2"	WHOLE			150'
W2X150	2" x 150' White Reflective Tape	2"		WHOLE		150'
Y2X150	2" x 150' Yellow School Bus Tape	2"			WHOLE	150'

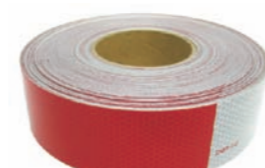

RW66-2X150

MODEL : FWR79B-ROADMASTER

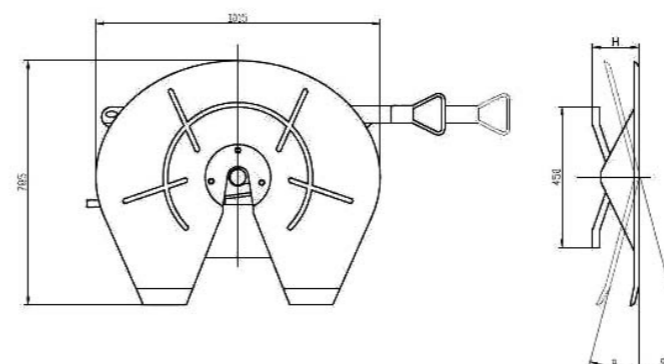

MODEL : FWR79B-ROADMASTER

ITEM ID	INSTALL HEIGHT	VERTICAL LOAD	D-VALUE	VERTICAL SWING ANGLE	NET WEIGHT (KG)
FWR79B1	185	28,000KG	190	15	212
FWR79B2	195			18	214

Exhaust Clamp

Style	Picture	Model#	
PRE-FORMED CLAMP		PFC300S/A PFC350S/A PFC400S/A PFC500S/A	3" lap joint, stainless steel/Aluminum 3.5" lap joint, stainless steel/Aluminum 4" lap joint stainless steel/Aluminum 5" lap joint stainless steel/Aluminum
FLAT BAND CLAMP		FBC250S/A FBC300S/A FBC350S/A FBC400S/A FBC500S/A FBC600S/A	2.5" flat band, stainless steel/Aluminum 3" flat band, stainless steel/Aluminum 3.5" flat band, stainless steel/Aluminum 4" flat band, stainless steel/Aluminum 5" flat band, stainless steel/Aluminum 6" flat band, stainless steel/Aluminum
EASY SEAL CLAMP		ESC300S/A ESC350S/A ESC400S/A ESC500S/A	3" flat band, stainless steel/Aluminum 3.5" flat band, stainless steel/Aluminum 4" flat band, stainless steel/Aluminum 5" flat band, stainless steel/Aluminum

Flare Kit



Item No.: FK-502
Standard : SAE.DOT
Packing : 144 or 162 sets / wooden crate
3060 sets (i.e.20 wooden crates)/20' container

Hub Cap



Item No.	Replace	Pcs/Ctn	Item No.	Replace	Pcs/Ctn
HC157619	Stemco 343-4009 Sirco 9009/9005	36pcs	HC157623	Stemco 343-4249 Sirco 9249	36pcs
HC157621	Stemco 343-4075 Sirco 9013	36pcs	HC157624	Stemco 343-4013 Sirco 9008	36pcs
HC157622	Stemco 343-4024 Sirco 9024	36pcs	HC157620	Stemco Sirco	36pcs

King Pin

Features :

- 1) Rated to 108KN, 174KN + 240KN
- 2) Manufactured from high tensile drop forgings and heat-treated
- 3) Complies with Australian standards as 2175-1995 and Australian design rules ADR 62/01
- 4) Designed to meet single trailer to be double and triple road train applications

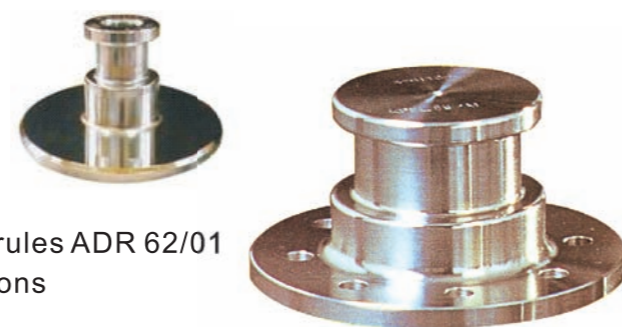

DISC. : 2" WELDED KINGPIN

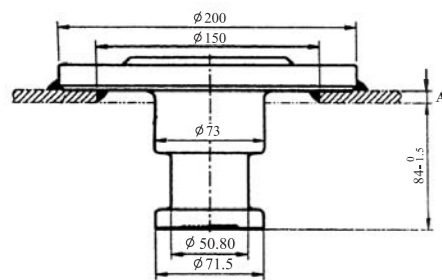

Model	D-Value	Skid Plate Thickness(A)
KPEW208	108KN	8
KPEW210	108KN	10

DISC. : 3 1/2" WELDED KINGPIN

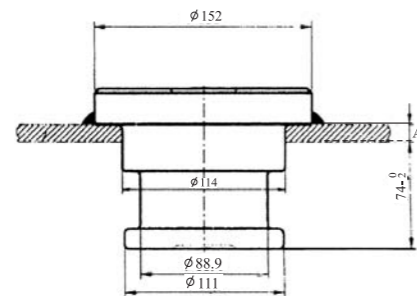

Model	D-Value	Skid Plate Thickness(A)
KPAW9010	174KN	10
KPAW9012	174KN	12

DISC. : 2" BOLT-IN DESIGN

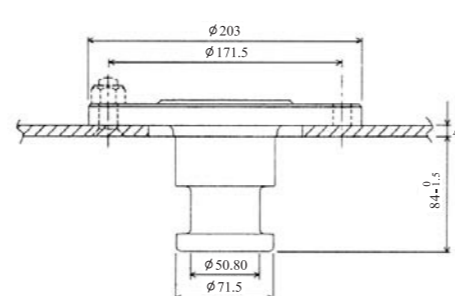

Model	D-Value	Skid Plate Thickness(A)
KPEB208	108KN	8
KPEB210	108KN	10

DISC. : 2" BOLT-IN KINGPIN ASSY

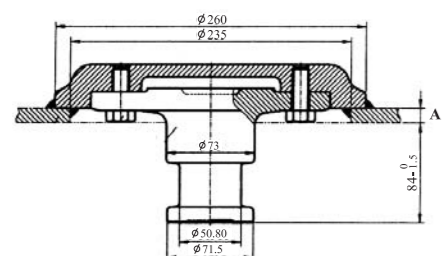

Model	D-Value	Skid Plate Thickness(A)
KPAB208	240KN	8
KPAB210	240KN	10
KPAB212	240KN	12
KPAB216	240KN	16

Note: The bolt torque settings: 190Nm

DISC. : 3 1/2" HD BOLT-IN KINGPIN ASSY

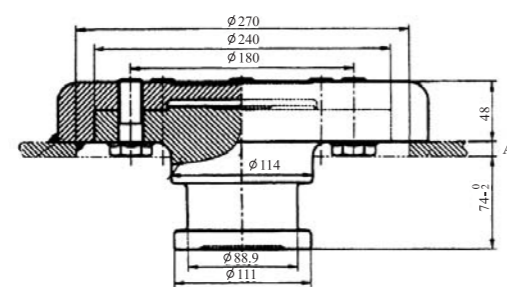

Model	D-Value	Skid Plate Thickness(A)
KPB9008	240KN	16

Note: The bolt torque settings: 500Nm

DISC. : ADAPTOR (2" TO 3 1/2" KINGPIN)

MODEL : MK 380505

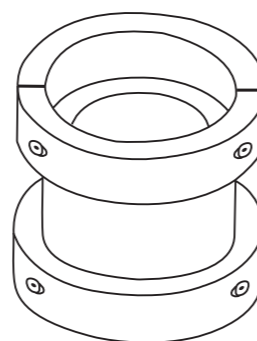

Note :
This adaptor does not increase load Capacity of 2" Kingpin and should only be used for handling operations, allowing trailer to be coupled to tractor unit with 3.5" Coupler.

DISC. : 3 1/2" BOLT-IN KINGPIN ASSY

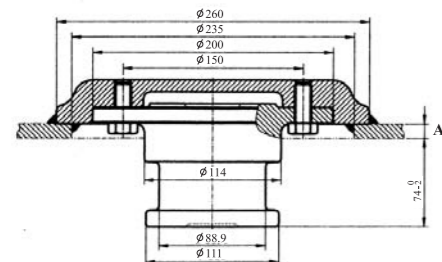

Model	D-Value	Skid Plate Thickness(A)
KPAB9008	240KN	8
KPAB9010	240KN	10
KPAB9012	240KN	12
KPAB9016	240KN	16

Note: The bolt torque settings: 190Nm

DISC. INTERCHANGEABLE OF 2" & 3 1/2" BOLT-IN KING PIN

2" bolt-in king pin only
Model : KPAB212-0100

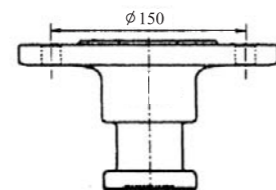

3 1/2" bolt-in king pin only
Model : KPAB9012-0100

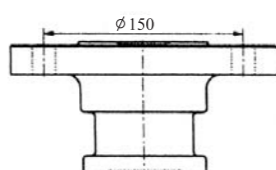

DISC. : RETENTION PLATE ONLY

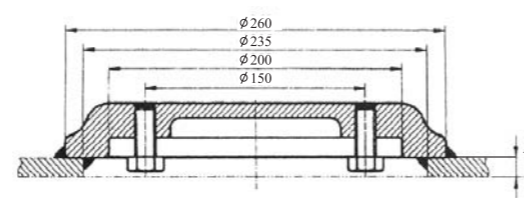

Model	Skid Plate Thickness(A)
KPAB208-0200	8
KPAB210-0200	10
KPAB212-0200	12
KPAB216-0200	16

Landing Gear

60,000 SERIES MAINTENANCE FREE SEMI-TRAILER LANDING GEAR

STANDARD SPECIFICATION

- Capacity : 28,000kg/pair
: 61,600 lb/pair
- Static load : 80,000kg/pair
: 176,000 lb/pair
- Weight : 98kg
: 215.6lb
- Low gear : 0.42 mm Per Turn (mm/r) of Handle
- High gear : 3.5 mm Per Turn (mm/r) of Handle
- One side operation : 28T-35kg crank force
: 28T-77lb
- Two side operation : 28T-17kg crank force
: 28T-37.4lb

Features :

- 1) Wider square sections of 130MM
- 2) Full flange reinforcement
- 3) Standard mounting plate
- 4) 480MM or 430MM lift
- 5) Bigger sand shoes
- 6) Gearbox with low temperature premium chassis lube rated for service from - 30°C to 120°C
- 7) Maintenance free feature with grease packed jack screw
- 8) Lower crank force
- 9) Meets TTMA, AAR and German safety regulations for commercial vehicles

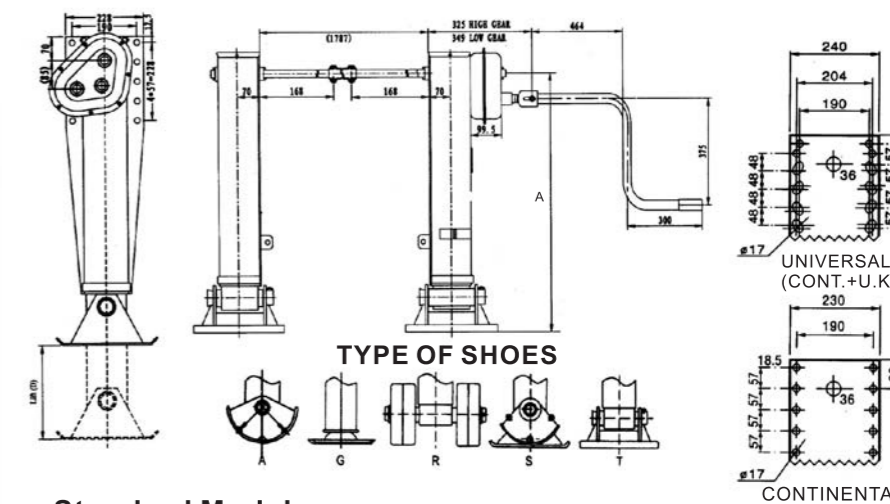

Standard Models

Standard Models	Types of Shoes	Lift(D)		Height(A)	
		mm	inch	mm	inch
LG280001A	A	430	16.93"	814	32.05"
LG280001G	G	430	16.93"	770	30.31"
LG280001R	R	430	16.93"	797	31.38"
LG280001S	S	430	16.93"	830	32.68"
LG280001T	T	430	16.93"	794	31.26"

Standard Models	Types of Shoes	Lift(D)		Height(A)	
		mm	inch	mm	inch
LG280002A	A	480	18.90"	864	34.02"
LG280002G	G	480	18.90"	820	32.28"
LG280002R	R	480	18.90"	847	33.35"
LG280002S	S	480	18.90"	880	34.65"
LG280002T	T	480	18.90"	844	33.23"

H22,000 SERIES HIGH SPEED LITE WEIGHT MAINTENANCE FREE SEMI-TRAILER LANDING GEAR

STANDARD SPECIFICATION

- Capacity : 24,000kg/pair
: 52,800 lb/pair
- Static load : 50,000 kg/pair
: 110,000 lb/pair
- Weight : 92kg
: 202.4lb
- Low gear : 0.9 mm Per Turn (mm/r) of Handle
- High gear : 9 mm Per Turn (mm/r) of Handle
- One side operation : 24T-32kg crank force
: 24T-70.4lb
- Two side operation : 28T-16kg crank force
: 28T-35.2lb

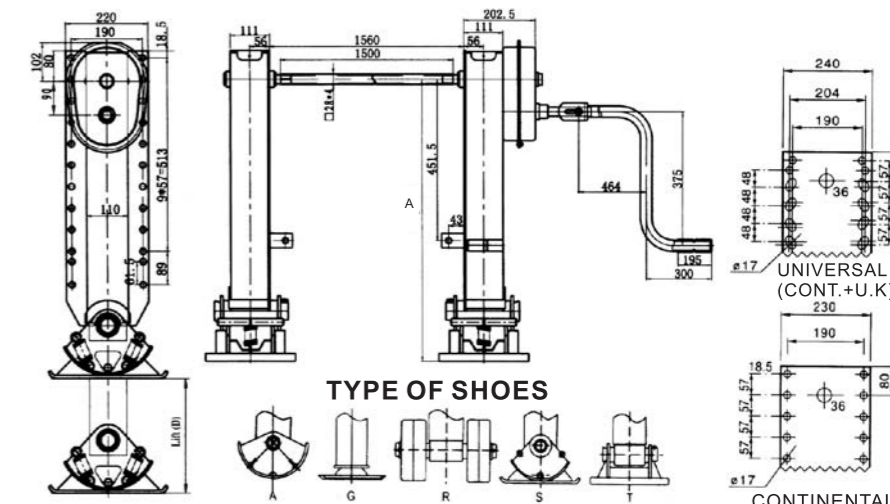
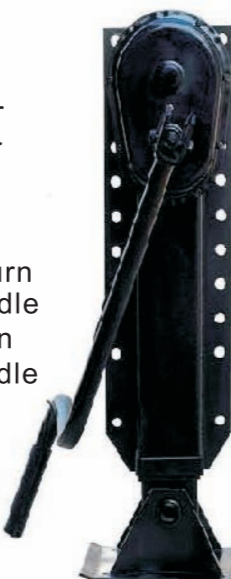

Standard Models

Standard Models	Types of Shoes	Lift(D)		Height(A)	
		mm	inch	mm	inch
LG220001A	A	430	16.93"	823	32.40"
LG220001LG	LG	430	16.93"	780	30.71"
LG220001R	R	430	16.93"	765	30.12"
LG220001S	S	430	16.93"	840	33.07"
LG220001T	T	430	16.93"	803	31.62"

Standard Models	Types of Shoes	Lift(D)		Height(A)	
		mm	inch	mm	inch
LG220002A	A	480	18.90"	823	32.40"
LG220002LG	LG	480	18.90"	830	32.68"
LG220002R	R	480	18.90"	815	32.09"
LG220002S	S	480	18.90"	880	34.65"
LG220002T	T	480	18.90"	853	33.58"

Features :

- 1) 100% dust proof + greaseless
- 2) High speed operation
- 3) Full flange mounting plate of continental or universal version
- 4) 480MM or 430MM lift
- 5) Bigger sand shoes
- 6) Gearbox with low temperature premium chassis lube rated for service from - 30°C to 120°C
- 7) Maintenance free feature with grease packed jack screw
- 8) Meets TTMA, AAR and German safety regulations for commercial vehicles

Leaf Spring



Part No .	Leaves	Arch (mm)	Main Leaf Flat Diameter (mm)	Replace	Part No .	Leaves	Arch (mm)	Main Leaf Flat Diameter (mm)	Replace
LS182256	7	108	1111	TRA-2256	LS182741	3	86/78	1070	TRA-2741
LS182726	3	159/144.5	1139	TRA-2726	LS18693	3	105.5	1034	TRA-693
LS182727	3	124/105	1091	TRA-2727	LS18696	9	63.5	1056	TRA-696
LS182728	3	97/89	1080	TRA-2728	LS18697	3	35.8	1083	TRA-697
LS182740	3	146/131.8	1098	TRA-2740	LS18699	4	106	1041	TRA-699

Note : contact us for other models

Mud Flap Hanger

MODEL : MFH2657 (Black)

STD PK/PALLET
30 PAIRS



- 1) Heavy Duty Spring Loaded
- 2) 30.25" Straight 1.18" Bolt Spacing

MODEL : MFH2657NT (Black)

STD PK/PALLET
30 PAIRS



- 1) Heavy Duty Spring Loaded
- 2) 30.25" Straight 1.18" Bolt Spacing

MODEL : MFH2657SNT (Stainless Steel)

STD PK/PALLET
30 PAIRS



- 1) Heavy Duty Spring Loaded
- 2) 30.25" Straight 1.18" Bolt Spacing

MODEL : MFH2667 (Black)

STD PK/PALLET
22 PAIRS



- 1) Heavy Duty Spring Loaded
- 2) 30.25" Straight 1.18" Bolt Spacing

MODEL : MFH2667NT (Black)

STD PK/PALLET
22 PAIRS



- 1) Heavy Duty Spring Loaded
- 2) 30.25" Straight 1.18" Bolt Spacing

MODEL : MFH2667S (Stainless Steel)

STD PK/PALLET
22 PAIRS



- 1) Heavy Duty Spring Loaded
- 2) 30.25" Straight 1.18" Bolt Spacing

Mud Flap

RUBBER (ECONOMY 1/4")

P/N	Desc
MF2424R	24"×24"
MF2430R	24"×30"
MF2436R	24"×36"

PLASTIC

P/N	Description
MF2424PSB	24"×24" Black
MF2424PSW	24"×24" White
MF2430PSB	24"×30" Black
MF2436PSB	24"×36" Black
MF2436PSW	24"×36" White

PREMIUM W/WIRE MESH

P/N	Desc
MF2424PR	24"×24"
MF2430PR	24"×30"
MF2436PR	24"×36"
MF2440PR	24"×40"

Oil Seal

Same Design As CR

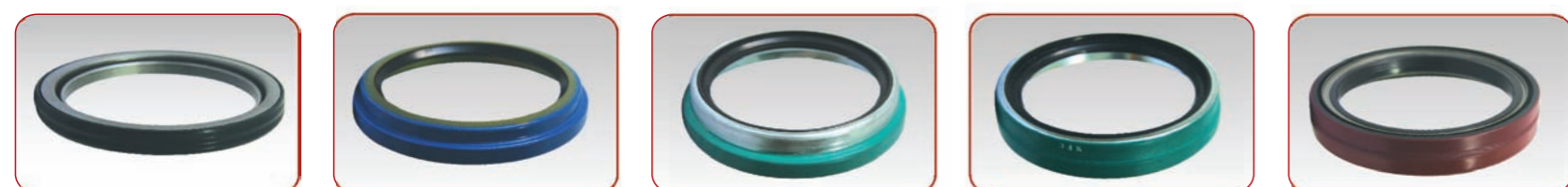

Part No.	Shaft Dia.	Bore Dia.	Seal Width.	National No.
OS27403937001	2.740	3.937	0.565	370155A
OS27523937002	2.752	3.937	0.565	370127A
OS34374755014	3.437	4.755	0.605	370047A
OS35004450016	3.500	4.450	0.843	370179A
OS35004842018	3.500	4.842	0.925	370001A
OS38755501025	3.875	5.501	0.890	370024A
OS38755690023	3.875	5.690	0.875	370023A
OS40005757032	4.000	5.757	0.930	370036A
OS42506008037	4.250	6.008	1.000	370065A
OS42506035038	4.250	6.035	0.915	370107A
OS42506048039	4.250	6.048	0.680	376590A
OS42506250036	4.250	6.250	1.375	370031A
OS43755905041	4.375	5.905	1.000	370048A
OS43755905045	4.375	5.905	1.000	370182A
OS43756251046	4.375	6.251	0.605	370019A
OS43756311044	4.375	6.311	1.090	370034A
OS45005374048	4.500	5.374	0.984	370124A
OS45005500055	4.500	5.500	0.675	370178A
OS45005750052	4.500	5.750	0.960	370022A
OS45005876050	4.500	5.876	0.984	370131A
OS45006000054	4.500	6.000	0.984	370020A
OS45006251053	4.500	6.251	1.047	370021A
OS46255999056	4.625	5.999	1.000	370025A
OS47656250062	4.765	6.250	0.565	370173A
OS47656251063	4.765	6.251	0.605	370005A
OS47656311059	4.765	6.311	1.187	370003A
OS48756622067	4.875	6.622	1.000	370109A
OS52507375076	5.250	7.375	1.000	370069A
OS55007125078	5.500	7.125	1.187	370043A
OS73759054086	7.375	9.054	1.062	370082A
OS787510234087	7.875	10.234	0.605	370151A

Plugs & Socket



P/N	Description	SIn Cross	Ph Cross	Hm Cross	Vlv Cross
PS15326	Dual Pole Receptacle	—	15-326	—	593121
PS15336	Dual Plug w/Spring	—	15-336	—	593116
PS23101	Single Pole Receptacle	421126	15-320	BE23101	591113
PS23102	Single Pole Plug	421127	15-335	BE23102	591105
PS23402*	4-Way Socket	421176	15-400	BE23402	055056
PS23403*	4-Way Plug	421131	15-410	BE23403	055054
PS23404	4-Way Plug w/Spring	421175	15-430	BE23404	—
PS23602*	6-Way Socket	421123	15-600	BE23602	055052
PS23603*	6-Way Plug	421135	15-610	BE23603	055050
PS23604	6-Way Plug w/Spring	421122	15-630	BE23604	593106
PS23712	ISO Socket	421163	16-7402	BE23712	593083
PS7S	7-Way Socket (Solid Pin)	421015	15-721	BE23703	593084
PS23782*	7-Way Socket (Split Pin)	421015	15-720	BE23703	593024
PS23783*	7-Way Plug	421000	15-710	BE23783	593022
PS23784*	7-Way Plug w/Spring	421001	15-730	BE23784	593022
PS23790	ISO Plug	421162	15-830	BE23790	593101
PS27407	6-7 Way Adapter	—	—	—	591010
PS27408	7-6 Way Adapter	—	—	—	591009
PS205010	7-Way Socket Boot	—	15-740	BE205010	055063



P/N	Description	SIn Cross	Ph Cross	Hm Cross	Vlv Cross
PS30400	4-Way Plug Scrubber	—	—	—	—
PS30600	6-Way Plug Scrubber	—	—	—	—
PS30700	7-Way Plug Scrubber	422203	4-121	BE20400	055034
PS34211	Plug/Gladhand Caddy	441747	—	11514	—
PS11750	CH Stor-a-Way Plug Holder	—	—	—	—

***AVAILABLE IN 10 PACKS**

PS24000	7-Way Socket w/o Circuit Breaker	—	16-760	—	055040
PS24001	7-Way Socket w/o Circuit Breaker	421053	—	—	—
PS24020	7-Way Socket w/cb 20 Amp.	421019	16-767	—	055037
PS15769	Housing for 7-Way w/Breakers	—	—	—	—

Slack Adjuster (Manual)

A-series Manual Slack Adjuster



P/N	Midland No.	Bush Dia.				Hole Dia.	Spline
		A	B	C	D		
SA2010AF	KN47001	5"	6"	7"	—	1/2"	10 splines
SA2020AF	KN47011	5 1/2"	6 1/2"	—	—	1/2"	10 splines
SA2021AF	KN47081	5"	6"	—	—	1/2"	10 splines
SA 18048AF	18-048	5"	6"	7"	8"	1/2"	10 splines
SA18057AF	18-057	127	152	178	203	14mm	10 splines
SA18880AF	18-880	4 1/2"	5 1/2"	6 1/2"	7 1/2"	1/2"	10 splines
SA2011AF	KN44051	5"	6"	—	—	1/2"	28 splines
SA2019AF	KN44061	5 1/2"	6 1/2"	—	—	1/2"	28 splines
SA2022AF	KN44071	5"	6"	7"	—	1/2"	28 splines
SA2012AF	KN44041	—	6"	—	—	1/2"	37 splines
SA2023AF		5"	6"	—	—	1/2"	37 splines
SA2024AF	KN44042	5"	6"	7"	—	1/2"	37 splines
SA18116AF	18-116	5"	6"	7"	8"	1/2"	37 splines



B-series Manual Slack Adjuster

P/N	Midland No.	Bush Dia.				Hole Dia.	Spline
		A	B	C	D		
SA278323	KN47001	5"	6"	7"	—	1/2"	10 splines
SA278321	KN47011	5 1/2"	6 1/2"	—	—	1/2"	10 splines
SA278312	KN47081	5"	6"	—	—	1/2"	10 splines
SA278326	KN47001	5 1/2"	6 1/2"	—	—	1/2"	10 splines
SA278302	KN48031	4 1/2"	5 1/2"	—	—	1/2"	10 splines
SA278303	KN48001	5"	6"	—	—	1/2"	10 splines
SA278305	KN48002	5"	6"	7"	—	1/2"	10 splines
SA288282	KN44071	5"	6"	7"	—	1/2"	28 splines
SA288753	KN44061	5 1/2"	6 1/2"	—	—	1/2"	28 splines
SA286965	KN44051	5"	6"	—	—	1/2"	28 splines
SA283411	KN44041	—	6"	—	—	1/2"	37 splines
SA61137370	—	5"	6"	7"	—	1/2"	37 splines

Offset Manual Slack Adjuster



Part NO.	Rated Torque	Spline Size	Body Parameter					Straight/Offset	Pin Hole
			A	B	C	D	OAL		
SA288539	PL20	1-1/2" -10	5.5"	6.5"	—	—	193MM	RH-1.5"	1/2"
SA288541	PL20	1-1/2" -10	5"	6"	—	—	193MM	RH-1.5"	1/2"
SA279350	PL20	1-1/2" -10	7"	—	—	—	193MM	RH-1.5"	1/2"
SA287896	PL20	1-1/2" -28	5.5"	6.5"	—	—	193MM	RH-1.5"	1/2"
SA101414	PL20	1-1/2" -28	5.5"	—	—	—	193MM	RH-1.5"	1/2"



Part NO.	Rated Torque	Spline Size	Body Parameter					Straight/Offset	Pin Hole
			A	B	C	D	OAL		
SA288540	PL20	1-1/2" -10	5.5"	6.5"	—	—	193MM	LH-1.5"	1/2"
SA288542	PL20	1-1/2" -10	5"	6"	—	—	193MM	LH-1.5"	1/2"
SA279351	PL20	1-1/2" -10	7"	—	—	—	193MM	LH-1.5"	1/2"
SA287897	PL20	1-1/2" -28	5.5"	6.5"	—	—	193MM	LH-1.5"	1/2"
SA101413	PL20	1-1/2" -28	5.5"	—	—	—	193MM	LH-1.5"	1/2"



Part NO.	Rated Torque	Spline Size	Body Parameter					Straight/Offset	Pin Hole
			A	B	C	D	OAL		
SA279946	PL26	1-1/2" -10	6"	7"	—	—	193MM	RH-5/8"	1/2"
SA282560	PL26	1-1/2" -10	5.5"	6.5"	—	—	193MM	RH-5/8"	1/2"



Part NO.	Rated Torque	Spline Size	Body Parameter					Straight/Offset	Pin Hole
			A	B	C	D	OAL		
SA279947	PL26	1-1/2" -10	6"	7"	—	—	193MM	LH-5/8"	1/2"
SA282561	PL26	1-1/2" -10	5.5"	6.5"	—	—	193MM	LH-5/8"	1/2"

E-series European Style Manual



P/N	Original No.	Spline	Bush Dia.						
			A-φ	B-φ	C-φ	D-φ	E-φ	F-φ	G-φ
SA788213	05.174.65.13.0	10	120/14	135/14	150/14	165/14	180/14	195/14	250/14
SA788214	05.174.52.34.0	10	120/14	150/14	180/14	—	—	—	—
SA788217	05.174.52.61.0	10	120/14	150/14	180/14	220/14	250/14	—	—
SA788714	0351.949	10	152/12.7	—	—	—	—	—	—
SA788715	0351.950	10	152/12.7	—	—	—	—	—	—
SA788718	1505.325	10	140/12.7	165/12.7	—	—	—	—	—
SA788719	1505.324	10	140/12.7	165/12.7	—	—	—	—	—
SA788808	13.180	10	127/14	152/14	178/14	203/14	—	—	—
SA788404	346.420.17.38	26	145/14	—	—	—	—	—	—
SA788405	346.420.18.38	26	145/14	—	—	—	—	—	—
SA788106	281.852	27	125/14	155/14	185/14	210/14	245/14	—	—
SA788107	281.853	27	125/12.7	155/12.7	185/12.7	210/12.7	245/12.7	—	—
SA788105	767.0058	37	105/14	130/14	150/14	180/14	215/18	—	—

PI35 Manual



PART NUMBER	ANGLE	SPLINE SIZE	ARM LENGTH	BUSH HOLE
101918	0°	1-3/4" -10B	8-1/2"	19 mm

Slack Adjuster (Automatic)

Automatic Slack Adjuster (Replace Haldex Type)

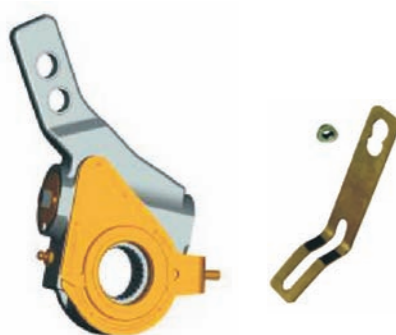

PART NUMBER	ANGLE	SPLINE SIZE	ARM LENGTH	BUSH HOLE
ASH10100	33°	1-1/2" -28	5"-6"	5/8"
ASH10101	33°	1-1/2" -28	5-1/2"-6-1/2"	5/8"
ASH10102	33°	1-1/2" -10	5"-6"	5/8"
ASH10103	33°	1-1/2" -10	5-1/2"-6-1/2"	5/8"
Supplied with Kits			3937101	



PART NUMBER	ANGLE	SPLINE SIZE	ARM LENGTH	BUSH HOLE
ASH10144	17°	1-1/2" -28	6"	1/2"
ASH10145	17°	1-1/2" -10	6"	1/2"
ASH10146	17°	1-1/2" -28	5-1/2"-6-1/2"	1/2"
Supplied with Kits			3937102	



PART NUMBER	ANGLE	SPLINE SIZE	ARM LENGTH	BUSH HOLE
ASH10211	0°	1-1/2" -28	5-1/2"	1/2"
ASH10212	0°	1-1/2" -28	6"	1/2"
ASH10213	0°	1-5/8" -37	5-1/2"	1/2"
ASH10214	0°	1-5/8" -37	6"	1/2"
ASH10215	0°	1-1/2" -10	5-1/2"	1/2"
ASH10216	0°	1-1/2" -10	6"	1/2"
Supplied with Kits			3937103	

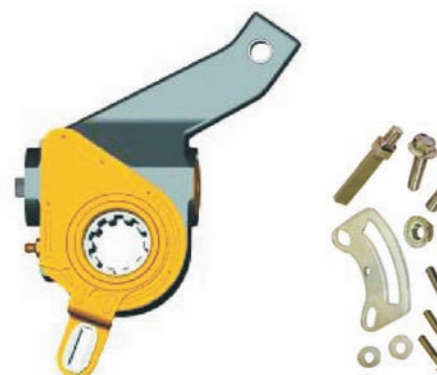

PART NUMBER	ANGLE	SPLINE SIZE	ARM LENGTH	BUSH HOLE
ASH10302	35°	1-1/2" -10	5"-6"	1/2"
ASH10304	35°	1-1/2" -28	5-1/2"	1/2"
ASH10305	35°	1-1/2" -28	6"	1/2"
ASH10306	35°	1-1/2" -10	6"	
ASH10307	35°	1-5/8" -37	6"	
Supplied with Kits			3937103	



PART NUMBER	ANGLE	SPLINE SIZE	ARM LENGTH	BUSH HOLE
ASH10504	20°	1-1/2" -10	5" 5-1/2" 6" 7"	1/2"
Supplied with Kits			3937103	



PART NUMBER	ANGLE	SPLINE SIZE	ARM LENGTH	BUSH HOLE
ASH10500	20°	1-1/2" -10	120mm 135 mm 153 mm 165 mm 180 mm	14 mm
Supplied with Kits			3937104	



PART NUMBER	ANGLE	SPLINE SIZE	ARM LENGTH	BUSH HOLE
ASH10505	20°	1-5/8" -37	115mm 127mm 140mm 153 mm 205 mm	14 mm
Supplied with Kits			3937105	



PART NUMBER	ANGLE	SPLINE SIZE	ARM LENGTH	BUSH HOLE
ASH79090	0°	1-1/2" -10	5" 6" 7" 8"	14 mm
Supplied with Kits			3937106	

Automatic Slack Adjuster (Replace Bendix Type)

Part Number	Spline Size	Arm Length	Yoke Offset	Adapter Thread	Lube Fitting	Replace
ASB107109	1-1/2" -10	5"	Straight	5/8" -18	0°	107109
ASB109357	1-1/2" -10	5"	Straight	5/8" -18	0°	109357
ASB107103	1-1/2" -10	5-1/2"	Straight	5/8" -18	0°	107103
ASB131026	1-1/2" -10	5-1/2"	Straight	5/8" -18	45°	131026
ASB107100	1-1/2" -10	6"	Straight	5/8" -18	0°	107100
ASB108617	1-1/2" -10	6"	Straight	5/8" -18	45°	108617
ASB107110	1-1/2" -28	5"	Straight	5/8" -18	0°	107110
ASB107105	1-1/2" -28	5-1/2"	Straight	5/8" -18	0°	107105
ASB107688	1-1/2" -28	5-1/2"	Straight	1/2" -20	0°	107688
ASB107689	1-1/2" -28	5-1/2"	Straight	1/2" -20	45°	107689
ASB108371	1-1/2" -28	5-1/2"	Straight	5/8" -18	90°	108371
ASB107127	1-1/2" -28	6"	Straight	5/8" -18	0°	107127
ASB108091	1-1/2" -28	6"	Straight	5/8" -18	90°	108091
ASB108093	1-1/2" -28	6"	Straight	5/8" -18	90°	108093
ASB107254	1-5/8" -37	5-1/2"	Straight	5/8" -18	0°	107254
ASB107280	1-5/8" -37	5-1/2"	Straight	5/8" -18	45°	107280
ASB107408	1-5/8" -37	5-1/2"	Straight	5/8" -18	0°	107408
ASB107409	1-5/8" -37	5-1/2"	Straight	5/8" -18	45°	107409
ASB107264	1-5/8" -37	6"	Straight	5/8" -18	0°	107264
ASB107279	1-5/8" -37	6"	Straight	5/8" -18	45°	107279
ASB107281	1-5/8" -37	6"	Straight	5/8" -18	45°	107281



Automatic Slack Adjuster (Replace Crewson Type)

Part Number	Spline Size	Arm Length	Yoke Offset	Adapter Thread	Lube Fitting	Replace
ASC21102	1-1/2" -10	5-1/2" 6-1/2"	Straight	5/8" -18	90°	21102
ASC21103	1-1/2" -10	5" 6"	Straight	5/8" -18	90°	21103
ASC21112	1-1/2" -10	5" 6" 7"	Straight	5/8" -18	90°	21112
ASC22102	1-1/2" -28	5-1/2" 6-1/2"	Straight	5/8" -18	90°	22102
ASC22103	1-1/2" -28	5" 6"	Straight	5/8" -18	90°	22103
ASC22112	1-1/2" -28	5" 6" 7"	Straight	5/8" -18	90°	22112
ASC23102	1-5/8" -37	5-1/2" 6-1/2"	Straight	5/8" -18	90°	23102
ASC23106	1-5/8" -37	6"	Straight	5/8" -18	90°	23106

Automatic Slack Adjuster (Replace Meritor Type)

Part Number	Spline Size	Arm Length	Yoke Offset	Clevis Thread	Use With Chamber Size	Replace
ASM801041	1-1/2" -10	5-1/2"	Straight	5/8" -18	24 , 30	R801041
ASM801043	1-1/2" -10	5-1/2"	Straight	5/8" -18	36	R801043
ASM801042	1-1/2" -10	6"	Straight	5/8" -18	30	R801042
ASM801040	1-1/2" -10	6"	Straight	5/8" -18	20 , 24	R801040
ASM801044	1-1/2" -10	6"	Straight	5/8" -18	36	R801044
ASM801077	1-1/2" -28	5"	Straight	5/8" -18	20, 24, 30	R801077
ASM801073	1-1/2" -28	5-1/2"	Straight	5/8" -18	24, 30	R801073
ASM801070	1-1/2" -28	5-1/2"	Straight	1/2" -20	16	R801070
ASM801079	1-1/2" -28	5-1/2"	Straight	5/8" -18	20	R801079
ASM801072	1-1/2" -28	5-1/2"	Straight	5/8" -18	20, 24, 36	R801072
ASM801074	1-1/2" -28	6"	Straight	5/8" -18	30	R801074
ASM801075	1-1/2" -28	6"	Straight	5/8" -18	36	R801075
ASM801101	1-5/8" -37	5-1/2"	Straight	5/8" -18	24 , 30	R801101
ASM801102	1-5/8" -37	6"	Straight	5/8" -18	30	R801102
ASM801100	1-5/8" -37	6"	Straight	5/8" -18	20, 24	R801100

Suspension Series

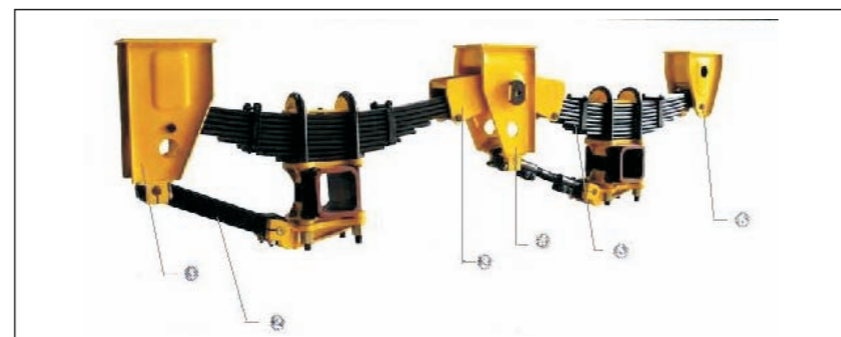

Features:

- Reliable proven design
- Australia ADR approved
- Taper bushing or greaseless powdered metal bushing for high durability
- High strength material for longer life at higher loads
- Simple maintenance

1. Front Hanger
2. Radius Rod Assembly
3. Equalizer
4. Equalizer Hanger
5. Leaf Spring
6. Rear Hanger

SUS88 Type Suspension Series

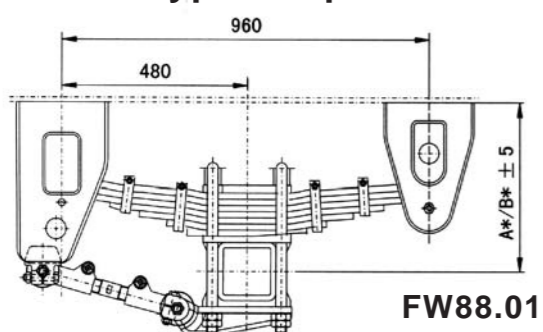

FW88.01 Single Suspension With Seven Leaf Springs

Model	Height of Towing Plate (mm)	A(mm)	B(mm)	Axle Load (kg)
SUS880201A	1180	441	411	13,000 * 1
SUS880202A	1220	481	451	13,000 * 1
SUS880203A	1250	511	481	13,000 * 1

SUS86 Type Heavy Duty Underslung Suspension Series

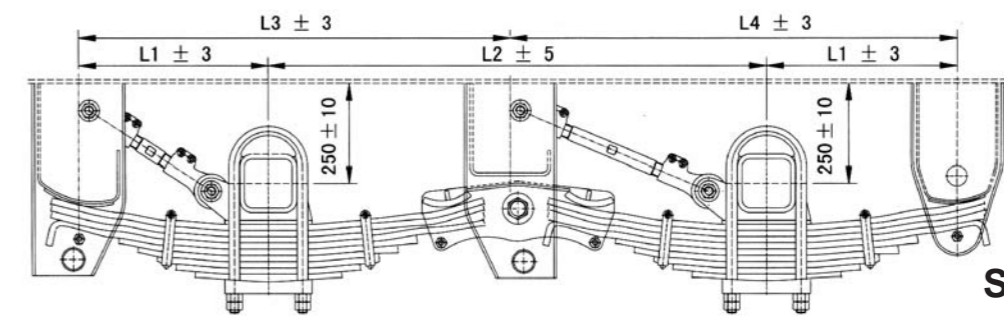

SUS86.02

SUS86.21/250/BQ6/9 Tandem Underslung Suspension With Nine Leaf Springs 1310

Model	L1(mm)	L2(mm)	L3(mm)	L4(mm)	Axle Load (kg)
SUS86.21/250/BQ6/9	495	1310	1135	1165	16,000 * 2

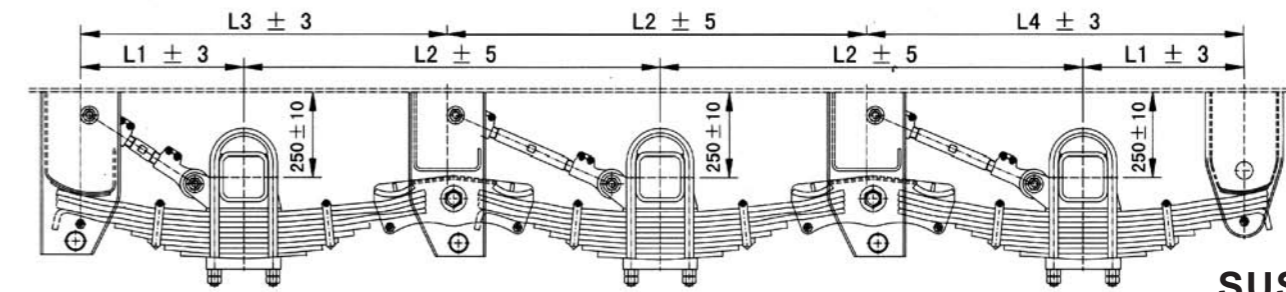

SUS86.03

SUS86.31/250/BQ6/9 Tri Underslung Suspension With Nine Leaf Springs 1310

Model	L1(mm)	L2(mm)	L3(mm)	L4(mm)	Axle Load (kg)
SUS86.31/250/BQ6/9	495	1310	1135	1165	16,000 * 3

SUS52 Air Suspension Series

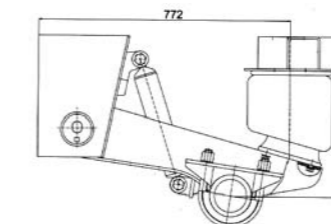

SUS52 Air Suspension Series

Model	H(mm)	Axle Load (kg)
SUS5211	356~483	11,000
SUS5213	381~610	13,000

SUS Argo Bogie Suspension Series

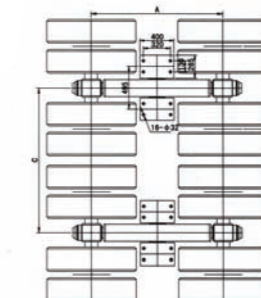
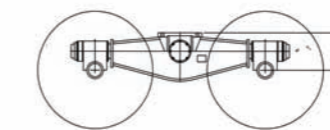

SUS Argo Bogie Suspension Series

Model	A(mm)	H(mm)	C(mm)	F(mm)	G(mm)	B(mm)	Recommended Tyre	Axle Load (kg)
SUS 40/1220/457	1220	457	1550	815	2840	260	8.25×15.18ply	40,000
SUS 80/1550/457	1550	457	1902	965	3400	414	12.00×24.16ply	60,000

SUS90(32T) Cantilever Dread Bogie Suspension

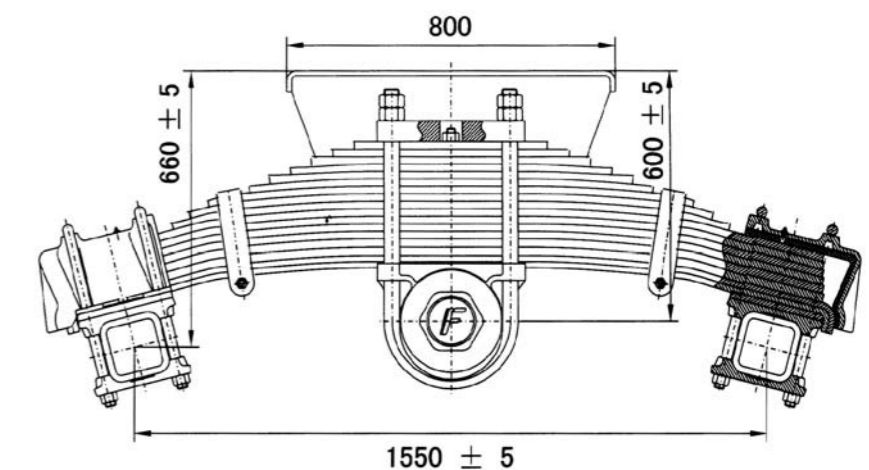
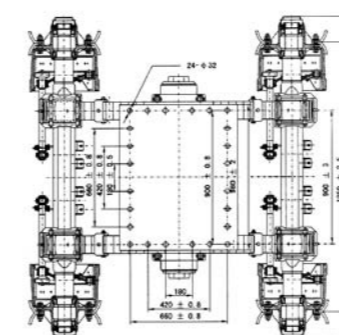

SUS90 (32T) Cantilever Dread Bogie Suspension

Axle Load (kg)	Recommended Tyre
32,000 kg	12,00R24

Note: (1) Different Type of Mounting Available
(2) Able to Suit All Brands of Round/Square Axles on Request

U-Bolt



P/N	Diam.(d) (MM)	Between Legs (b) (MM)	Leg Length (MM)	Thread	OE	FROM
UB-2415740400B0	24	157.4	400	M24	03.138.45.03.4	0
UB-2415740360B0	24	157.4	360	M24	03.138.45.07.4	0
UB-2412940433B0	24	129.4	433	M24	03.138.41.29.4	0
UB-2416940415B0	24	169.4	415	M24	03.138.42.01.4	0

U-Bolt Kit

Kit includes: 2 U-bolts, 4 washers & 4nuts



P/N	Diam.(d)	Between Legs (b)	Leg Length	Thread	Replace BWP	Replace Dayton
UBK-7830012	7/8"	3"	12"	7/8"-14	M-1499	361-248
UBK-7830014	7/8"	3"	14"	7/8"-14	M-1492	361-218
UBK-7830015	7/8"	3"	15"	7/8"-14	—	361-584
UBK-7830016	7/8"	3"	16"	7/8"-14	M1497	361-492
UBK-7830018	7/8"	3"	18"	7/8"-14	M1493	361-250
UBK-7831215	7/8"	3 1/2"	15"	7/8"-14	—	—
UBK-7850012	7/8"	5"	12"	7/8"-14	—	—
UBK-7850015	7/8"	5"	15"	7/8"-14	—	—

Wheel Hub

All hubs are with cups and without studs.
Hubs with studs can be special ordered.

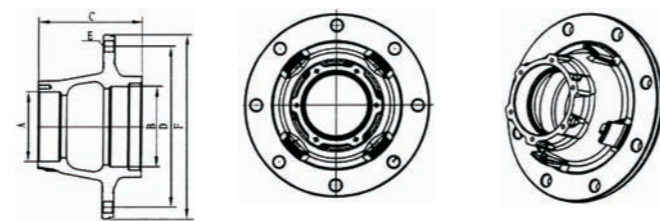

P/N	Webb P/N	Hole	Type	Inner Cup	Outer Cup	Bolt Circle	Pilot Dia
WH710019	10019N	10	Shoulder studs	HM218210 HM218248	Cup-HM212011 Cone-HM212049	11 1/4"	9 7/16"
WH712213	12213N	10	Shoulder studs	653 663/665A	Cup-HM212011 Cone-HM212049	11 1/4"	9 7/16"
WH71320Z	1320ZN	10	Serrated studs	HM518410 HM518445	Cup-HM518410 Cone-HM518445	11 1/4"	8 17/32"
WH710519	10519N	10	Shoulder studs	HM218210 HM218248	Cup-HM212011 Cone-HM212049	8 3/4"	7 1/8"
WH710209	10209N	10	Serrated studs	HM218210 HM218248	Cup-HM212011 Cone-HM212049	11 1/4"	8 17/32"
WH720231	20231-0™	10	Serrated studs	HM218210 HM218248	Cup-HM212011 Cone-HM212049	11 1/4"	8 3/4"
WH720231A	20231-0™	10	Serrated studs W/ABS Ring	HM218210 HM218248	Cup-HM212011 Cone-HM212049	11 1/4"	8 3/4"

Wheel Rim

Wheel Type	Wheel Size	Part No.	Bolt Holes		P.C.D	Center Bore	Offset	Thickness	
			Number	Diameter					
	» 6.50-20	6.50-20	WR650-20101	8	1.26"	10.83"	8.43"	5.71"	0.51"
	» 7.00-16	7.00-16	WR700-16101	6	0.81"	7.48"	5.51"	0	0.39"
	» 7.00T-20	7.00T-20	WR700-20106	10	1.02"	13.19"	11.06"	6.38"	0.51"
	» 7.50V-20	7.50V-20	WR750-20107	10	1.02"	13.19"	11.06"	6.50"	0.47"
	» 8.00V-20	8.00V-20	WR800-20104	10	1.06"	13.19"	11.06"	6.89"	0.55"
	» 8.50-20	8.50-20	WR850-20103	10	1.06"	13.19"	11.06"	6.89"	0.55"

17.5 SERIES 17.5X6.00 SERIES

Part No.	Size	Nut Hole			Center Hole	Thickness		Offset	Tyre	
		No.	Dia	Type		Rim	Disc			
WR-SHT205	17.5X6.00	6	φ 1.26"	SR22	φ 8.75"	φ 6.46"	0.20"	0.47"	5.04"	8R17.5
17.5X6.75 SERIES										
WR-SHT202	17.5X6.75	8	φ 1.02"	SR22	φ 10.83"	φ 8.70"	0.24"	0.47"	5.63"	9R17.5

19.5 SERIES 19.5X6.00 SERIES

WR-SHT207	19.5X6.00	6	φ 1.26"	SR22	φ 8.75"	6.46"	0.20"	0.47"	5.31"	8R19.5
19.5X6.75 SERIES										
WR-SHT210	19.5X6.75	8	φ 1.26"	SR22	φ 10.83"	8.43"	0.24"	0.47"	5.51"	9R19.5
19.5X7.5 SERIES										
WR-SHT237	19.5X7.5	10	φ 1.02"	SR18	φ 8.86"	6.93"	0.28"	0.47"	5.94"	10R19.5

22.5 SERIES 22.5X6.00 SERIES

WR-SHT212	22.5X6.00	8	φ 1.26"	SR22	φ 10.83"	φ 8.43"	0.20"	0.55"	5.31"	8.5R22.5
22.5X6.75 SERIES										
WR-SHT252	22.5X6.75	10	φ 1.02"	H1	φ 13.19"	φ 11.06"	0.24"	0.55"	6.14"	9R22.5
22.5X7.5 SERIES										
WR-SHT219	22.5X7.5	10	φ 1.02"	H1	φ 13.19"	φ 11.06"	0.28"	0.55"	6.50"	10R22.5
22.5X9.00 SERIES										
WR-SHT228	22.5X9.00	10	φ 1.02"	H1	φ 13.19"	φ 11.06"	0.28"	0.55"	6.89"	12R22.5
22.5X8.25 SERIES										
WR-SHT224	22.5X8.25	10	φ 1.02"	SR22	φ 13.19"	φ 11.06"	0.28"	0.55"	6.73"	11R22.5
22.5X11.75 SERIES										
WR-SHT230	22.5X11.75	10	φ 1.02"	H1	φ 13.19"	φ 11.06"	0.28"	0.55"	4.72"	385/65R22.5
24.5X8.25 SERIES										
WR-SHT232	24.5X8.25	10	φ 1.02"	H1	φ 11.25"	φ 8.66"	0.28"	0.63"	6.61"	11R24.5

Please contact us for more models

Wheel Stud & Nut

P/N	Replace Dayton	Replace BWP	Replace Euclid	Replace Sirco
Metric Serrated Studs				
MBA-2010219	—	M-3659	E10219	437
MBA-2010221	13-1552	M-3663	E10221	676
MBA-2010676	13-1577	M-3667	E10676	881M
MBA-205991	13-3050	M-3207	E5991	160
Clipped Collar Shoulder Studs				
MBA-205551L/R	13-1006L/R	M-57/56	E5551L/R	125/124
MBA-205553L/R	13-1008L/R	M-61/60	E5553L/R	272/271
MBA-205556L/R	13-1002L/R	M-49/48	E5556L/R	095/096
Front Wheel Studs				
MBA-205982L/R	13-1618L/R	M-2431/2430	E5982L/R	—
MBA-208972L/R	13-1630L/R	M-3633/3632	E8972L/R	—
Serrated Wheel Studs				
MBA-2010208L/R	—	M-3653/3652	E10208L/R	—
MBA-204965L/R	13-1102L/R	M-75/74	E4965L/R	192/191
MBA-204966L/R	13-1144L/R	—	E4966L/R	—
MBA-204967L/R	13-1103L/R	—	E4967L/R	—
Inner/Outer Cap Nuts				
MBA-205576L/R	13-3017L/R	—	E5576L/R	—
MBA-205579L/R	13-3016L/R	M-167/166	E5579L/R	913/912
MBA-205987L/R	13-3034L/R	—	E5987L/R	978L/R
MBA-205652L/R	13-3013L/R	M-125/124	E5652L/R	889L/888R



MBA-2010221



MBA-205551L/R



MBA-204965L/R

Other Accessories

Truck Hinge & Lock

-Truck Hinge

MATERIAL/FINISH:
A) NORMAL STEEL / ZINC-PLATED
B) AISI 304 / POLISH



KKH0002-SS

KKH0007-SS

KKH0006-SS

-Truck Lock

MATERIAL/FINISH:
A) NORMAL STEEL / ZINC-PLATED
B) AISI 304 / POLISH

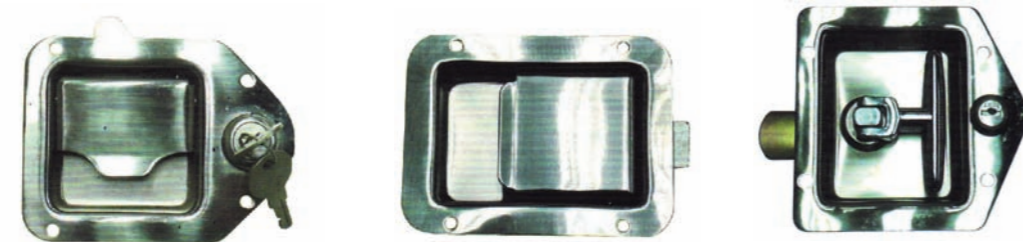

KKL0005

KKL0004S

KKL0002

-Twist Lock

150A TWIST LOCK

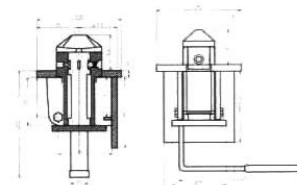

Model No.:150A
Description: Twist Lock
Packing:2pcs/carton

150B TWIST LOCK

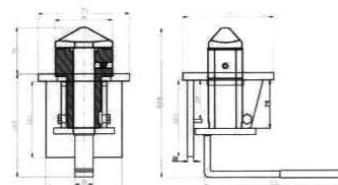

Model No.:150B
Description: Twist Lock
Packing:2pcs/carton

160A TWIST LOCK

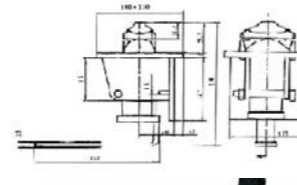

Model No.:160A
Description: Twist Lock
Packing:200pcs/pallet

230A TWIST LOCK

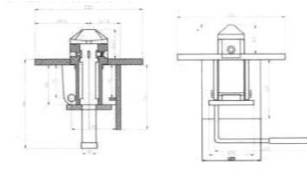

Model No.:230A
Description: Twist Lock
Packing:2pcs/carton

Van Rack



**TR101-S
Truck Rack**
LOAD CAPACITY
250lbs.

- Simple to Installation and dismantling When Not In Use
- Two Layers Shiny and Glossy Black Powder Coating
- Adjust Range from 24 " to 36 " Wide
- Mounts Directly to Truck Bed with Posts and Collared U-Bolts



**VR101-W
Van Rack**
LOAD CAPACITY
600lbs.

- Mounts Directly to Rain Gutter, Easy to Install
- Two Layers Shiny and Glossy Black Powder Coating
- Adjust Range from 41 " to 72 " Wide
- Pre-drilled End Plates for Tie Down Straps



**TR501-S
Truck Rack**
LOAD CAPACITY
1,000lbs.

- Mounts Directly to Bed Rail, Easy to Install
- Two Layers Shiny and Glossy Black Powder Coating
- Suitable for Pickup Truck Bed from 6-1/2' to 8'
- Can be Extended to Cab

World Class Products Professional Services



Wireless Back Up System

Background

Many deadly accidents happened on lorries or construction trucks because careless drivers could not see clearly at the rear end during reversing the vehicles. Currently the rear view systems used in long vehicles are hardwired solutions. It is costly and rigid to be installed. This wireless backup monitor system, provides a high quality image vision. Users can easily install DIY and it is economical to switch the device among various vehicles in a fleet.



Long Vehicle Wireless Backup Monitor System



Product Features

1. Wireless image transmission between camera and LCD monitor. Easy to install.
2. Digital frequency hopping design enables high reliability in resistant to noise interference.
3. Video signal can be displayed on user's own LCD console.

Deliverables

1. Fully tested reference design prototype overcoming the shielding effect of 40-foot metallic container.
2. Under the provisions to United States FCC Part 15 unlicensed low-power broadcasting requirements.



Basic Specifications

1. 2.4 to 2.478GHz ISM Band.
2. Operating transmission range (line-of-sight) up to 37meter.
3. Latency less than 0.25 second.
4. NTSC/PAL video format. Resolution at 320×240 pixels (QVGA), 16-bit color, 16fps.
5. Operating Voltage 6V (min) to 33V (max).

Target Users

1. Before-market or After-market automotive parts manufacturers.
2. Medium range surveillance system at home or office.



Analog Wireless Parking Camera



Digital Wireless Parking Camera

